



IHSV

Integrated ac servo motor manual



| Version | Editor | Verifier |
|---------|--------|----------|
| V2.0 | R&D | R&D |

Contents

| | |
|------------------------------------|-----------|
| 1. Overview | 错误!未定义书签。 |
| 2. Features | 4 |
| 3. Technical index | 5 |
| 4. Ports Introduction | 6 |

| | | |
|-----------|---|-----------|
| 4.1 | ALM signal output ports | 6 |
| 4.2 | Control Signal Input Ports | 7 |
| 4.3 | Power Interface Ports | 8 |
| 5. | Parameter and function | 8 |
| 5.1 | List of parameters | 8 |
| 5.2 | Parameter parsing instructions..... | 16 |
| 5.2.1 | P00-xx Motor and Drive Parameters | 16 |
| 5.2.2 | P01-xx Main control parameters | 18 |
| 5.2.3 | P02-xx Gain parameters | 21 |
| 5.2.4 | P03-xx Position parameters | 267 |
| 5.2.5 | P04-xx Speed parameter..... | 27 |
| 5.2.6 | P05-xx 8/5000Torque parameters..... | 28 |
| 5.2.7 | P06-xx I/O parameter | 280 |
| 5.2.8 | P08-xx Advanced function parameters..... | 30 |
| 5.3 | List of monitored items | 31 |
| 6. | Fault Analysis and Processing | 33 |
| 6.1 | Fault Alarm Information Form | 33 |
| 6.2 | Causes and Disposal of Fault Alarm | 36 |
| 7. | Control signal wiring..... | 40 |
| 7.1 | Control signal single terminal coanode wiring | 390 |
| 7.2 | Control signal single terminal cocathode wiring | 41 |
| 7.3 | Control signal differential wiring mode..... | 42 |
| 7.4 | 232Serial communication wiring..... | 43 |
| 7.5 | Control signal timing diagram | 44 |
| 7.6 | Chart of torque characteristic of servo motor speed | 45 |
| 8. | Subdivision code switch settings..... | 50 |
| 8.1 | Subdivision settings..... | 50 |
| 8.2 | Enter Edge Settings | 51 |
| 8.3 | logical Direction Settings | 51 |

| | |
|--|-----------|
| 9. Error alarm and LED light flicker times..... | 51 |
| 10. Installation dimensions(mm) | 52 |
| 11. Frequently Asked Questions and Fault Analysis | 56 |
| 11.1 Power's not on. | 56 |
| 11.2 Turn on the red light. | 56 |
| 11.3 Run, turn a small angle, turn on the red light..... | 56 |
| 11.4 After the pulse is entered, it does not rotate..... | 56 |
| 12. IHSV42/57/60/86-XX Parameter modification step..... | 57 |

1. Overview

IHSV42/57/60 / 86-XX Integrated AC servo drive motor integrates AC servo drive into servo motor. The two are perfectly integrated and use vector control designed and produced by DSP. It has the characteristics of low cost, full closed-loop, full number, low heat, small vibration and fast response. Includes three adjustable feedback loop controls(position loop, speed loop, and current loop). Performance stability, is a very high cost performance of sports control products.

2、 Features

- 2.1 Multiple pulse input modes Pulse + Direction
- 2.2 Optically coupled isolation servo reset input interface ERC
- 2.3 Current loop bandwidth:(-3 dB) 2 KHz(typical value)

- 2.4 Speed loop bandwidth: 500 Hz(typical value)
- 2.5 Position loop bandwidth: 200 Hz(typical value)
- 2.6 Motor end orthogonal encoder input interface: differential input(26LS32)
- 2.7 Download parameters via PC or text display with RS232C interface
- 2.8 Users can choose to subdivide through external dialing switches, or they can use software Define subdivision
- 2.9 Overflow, I2T, Overpressure, Speeding, Ultra-Poor Protection
- 2.10 A green light indicates operation, a red light indicates protection or offline

3、Technological Index

| | | 42base | | 57base | | | 60base | | 86base | |
|----------------------------|---------------------|---|---------|----------|----------|----------|----------|----------|----------|----------|
| | | 52 W | 78 W | 100 W | 140 W | 180 W | 200 W | 400 W | 440 W | 660 W |
| Input voltage (VDC) | | 24V | | 36V | | | 36V | 48V | 48V | 72V |
| Max pulse frequency | | 200K | | | | | | | | |
| Default communication rate | | 9.6Kbps (Additional interface required) | | | | | | | | |
| Protection | | ►Overload I2t Current Action Value 300 % 3S | | | | | | | | |
| Specifications | Environment | Avoid dust, oil fog and corrosive gases | | | | | | | | |
| | Working temperature | 0~+70℃ | | | | | | | | |
| | Storage temperature | -20℃~+80℃ | | | | | | | | |

| | | |
|--|----------------|---------------------------------------|
| | Humidity | 40~90%RH |
| | Cooling method | Natural cooling or forced air cooling |

4、Ports Introduction

4.1 ALM signal output ports

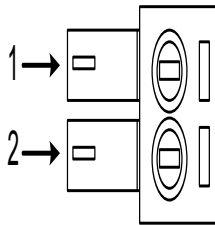

| Symbol | Name | Instruction |
|--------|-------------------------|-------------|
| ALM- | Alarm output - | |
| ALM+ | Alarm output + | |
| PED- | Arrive position output- | |
| PED+ | Arrive position output+ | |

4.2 Control Signal Input Ports

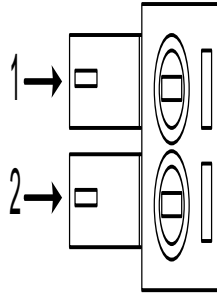

| Symbol | Function | Remark |
|--------|---|---------------------|
| ENA- | Enabling signal: This input signal is used to enable or prohibit; In addition, it can be used to clear the drive alarm. When ENA + is connected to +5 V, ENA-is connected to | Low 0 ~ 0.5 V valid |
| ENA+ | low power, the drive will cut off the current of each phase of the motor so that the motor is in a free state, where the pulse is not responded and the alarm can be cleared; When this function is not required, the energy signal end is suspended. | High 4 ~ 5V valid |
| DIR- | Direction signal: high/low level signal. In order to ensure | Low 0 ~ 0.5 V valid |
| DIR+ | the reliable direction change of the motor, the direction signal should be established before the pulse signal at least 6us. | High 4 ~ 5V valid |
| PUL- | Pulse control signal: Pulse rising edge is effective. In order | Low 0 ~ 0.5 V valid |
| PUL+ | to reliably respond to pulse signal, the pulse width should be greater than 2.5 us. | High 4 ~ 5V valid |

4.3 Power port

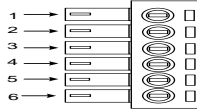

| Identification | Symbol | Name | Remark |
|----------------------|--------|---------|---|
| Power input terminal | DC+ | Power+ | 20VDC-80VDC(select voltage and power supply according to the corresponding type of motor's technical index) |
| | GND | Power - | |

5、 Parameters and function

5.1 Parameters list

- P00-xx Represents motor and drive parameters
- P01-xx Main control parameters
- P02-xx Represents the gain class parameter
- P03-xx Represents the position parameter
- P04-xx Represents the speed parameter
- P05-xx Represent the torque speed
- P06-xx Represent I/O parameter
- P08-xx Represents an advanced function parameter

| Model | Parameter code | Name | Setting range | Factor y setting | Unit | Setting way | Effective time |
|-----------------------------|----------------|--|---------------|------------------|--------------------|--------------|----------------|
| Motor and driver parameters | P00-00 | Motor No. | 0-65535 | --- | | Stop Setting | Re-power |
| | P00-01 | Motor rated speed | 1-6000 | --- | rpm | Stop Setting | Re-power |
| | P00-02 | Motor rated torque | 0.01-655.35 | --- | N.M | Stop Setting | Re-power |
| | P00-03 | Motor rated current | 0.01-655.35 | --- | A | Stop Setting | Re-power |
| | P00-04 | Motor inertia | 0.01-655.35 | --- | kg.cm ² | Stop Setting | Re-power |
| | P00-05 | Pole number of motor | 1-31 | --- | Opposite pole | Stop Setting | Re-power |
| Motor and driver parameters | P00-10 | Number of lines in incremental encoder | 0-65535 | --- | | Stop Setting | Re-power |
| | P00-11 | Incremental encoder Z pulse angle | 0-65535 | --- | | Stop Setting | Re-power |
| | P00-12 | Initial angle of rotor 1 | 0-360 | --- | 1degree | Stop Setting | Re-power |
| | P00-13 | Initial angle of rotor2 | 0-360 | --- | 1degree | Stop Setting | Re-power |
| | P00-14 | Initial angle of rotor3 | 0-360 | --- | 1degree | Stop Setting | Re-power |
| | P00-15 | Initial angle of rotor4 | 0-360 | --- | 1degree | Stop Setting | Re-power |

| | | | | | | | |
|-------------------------|------------|--|----------|-----|---------|--------------|-----------------------|
| | P00-1 6 | Initial angle of rotor5 | 0-360 | --- | 1degree | Stop Setting | Re-power |
| | P00-1 7 | Initial angle of rotor6 | 0-360 | --- | 1degree | Stop Setting | Re-power |
| | P00-2 1 | RS232 communicate baud rate | 0-3 | 2 | --- | Stop Setting | Re-power |
| | P00-2 3 | Slave address | 0-255 | 1 | --- | Stop Setting | Re-power |
| | P00-2 4 | Modbus =communicate baud rate | 0-7 | 7 | --- | Stop Setting | Re-power |
| | P00-2 5 | Check mode | 0-3 | 1 | --- | Stop Setting | Re-power |
| | P00-2 6 | ModbusCommunication response delay | 0-100 | 0 | 1ms | Stop Setting | Re-power |
| | P00-4 2 | Overvoltage protection threshold | 0-300 | 0 | 1V | Stop Setting | Re-power |
| Main control parameters | P01-0 1 | Control mode setting | 0-2 | 0 | --- | Stop Setting | Effective immediately |
| | P01-0 2 | Real time automatic adjustment mode | 0-2 | 1 | --- | Run Settings | Effective immediately |
| | P01-0 3 | Real time automatic adjustment of rigidity setting | 0-31 | 13 | --- | Run Settings | Effective immediately |
| | P01-0 | The ratio of | 0-100.00 | 1 | 1times | Run | Effective |

| | | | | | | | |
|----------------|--------|---|------------|------|------|--------------|-----------------------|
| | 4 | moment of inertia | | | | Settings | immediately |
| | P01-30 | Brake command - servo OFF delay time (brake open delay) | 0-255 | 100 | 1ms | Run Settings | Effective immediately |
| | P01-31 | Speed limit value of brake command output | 0-3000 | 100 | 1rpm | Run Settings | Effective immediately |
| | P01-32 | Servo OFF brake command waiting time | 0-255 | 100 | 1ms | Run Settings | Effective immediately |
| Gain parameter | P02-00 | Position control gain 1 | 0-3000.0 | 48.0 | 1/S | Run Settings | Effective immediately |
| | P02-01 | Position control gain 2 | 0-3000.0 | 57.0 | 1/S | Run Settings | Effective immediately |
| | P02-03 | Speed feedforward gain | 0-100.0 | 30.0 | 1.0% | Run Settings | Effective immediately |
| | P02-04 | Speed feedforward smoothing constant | 0-64.00 | 0.5 | 1ms | Run Settings | Effective immediately |
| | P02-10 | Speed proportional | 1.0-2000.0 | 27.0 | 1Hz | Run Settings | Effective immediately |

| Gain parameter | | gain1 | | | | s | |
|----------------|--------|--|------------|--------|------|---------------|-----------------------|
| | P02-11 | Speed integral constant 1 | 0.1-1000.0 | 10.0 | 1ms | Run Setting s | Effective immediately |
| | P02-12 | Pseudo differential feedforward control coefficient1 | 0-100.0 | 100.0 | 1.0% | Run Setting s | Effective immediately |
| | P02-13 | Speed proportional gain 2 | 1.0-2000.0 | 27.0 | 1Hz | Run Setting s | Effective immediately |
| | P02-14 | Velocity integral constant2 | 0.1-1000.0 | 1000.0 | 1ms | Run Setting s | Effective immediately |
| | P02-15 | Pseudo differential feedforward control coefficient2 | 0-100.0 | 100.0 | 1.0% | Run Setting s | Effective immediately |
| | P02-19 | Torque feedforward gain | 0-30000 | 0 | 1.0% | Run Setting s | Effective immediately |
| | P02-20 | Torque feed forward smoothing constant | 0-64.00 | 0.8 | 1ms | Run Setting s | Effective immediately |
| | P02-30 | Gain switching mode | 0-10 | 0 | --- | Run Setting | Effective immediately |

| | | | | | | | |
|----------|--------|---------------------------------|--------------|-------|------|---------------|-----------------------|
| | | | | | | s | |
| | P02-31 | Gain switching level | 0-20000 | 800 | --- | Run Setting s | Effective immediately |
| | P02-32 | Gain switching delay | 0-20000 | 100 | --- | Run Setting s | Effective immediately |
| | P02-33 | Gain switching delay | 0-1000.0 | 10.0 | 1ms | Run Setting s | Effective immediately |
| | P02-34 | Position gain switching time | 0-1000.0 | 10.0 | 1ms | Run Setting s | Effective immediately |
| | P02-41 | Mode switch level | 0-20000 | 10000 | --- | Run Setting s | Effective immediately |
| | P02-50 | The torque instruction is added | -100.0-100.0 | 0 | 1.0% | Run Setting s | Effective immediately |
| | P02-51 | Forward torque compensation | -100.0-100.0 | 0 | 1.0% | Run Setting s | Effective immediately |
| | P02-52 | Reverse torque compensation | -100.0-100.0 | 0 | 1.0% | Run Setting s | Effective immediately |
| location | P03-00 | Location command source | 0-1 | 0 | --- | Stop Setting | Effective immediately |
| | P03-03 | The command pulse is reversed | 0-1 | 0 | --- | Stop Setting | Effective immediately |

| | | | | | | | |
|-----------|--------|---|----------|------|---------------------|---------------|-----------------------|
| parameter | P03-04 | Position pulse filtering | 0-3 | 2 | --- | Run Settings | Effective immediately |
| | P03-05 | Positioning completes the judgment condition | 0-2 | 1 | --- | Run Settings | Effective immediately |
| | P03-06 | Location Completion range | 0-65535 | 30 | Encoder unit | Run Settings | Effective immediately |
| | P03-09 | Number of command pulses for one motor rotation | 0-65535 | 4000 | Pulse | Run Settings | Re-power |
| | P03-10 | Molecular of electronic gear 1 | 1-65535 | 4000 | --- | Run Settings | Re-power |
| | P03-11 | The denominator of electronic gear 1 | 1-65535 | 4000 | --- | Run Settings | Re-power |
| | P03-15 | Position deviation too large setting | 0-65535 | 0 | Instruction unit*10 | Run Settings | Effective immediately |
| | P03-16 | Position instruction smoothing filter time constant | 0-1000.0 | 0 | 1ms | Run Settings | Effective immediately |
| speed | P04-00 | Speed command | 0-1 | 1 | --- | Stop Settings | Effective immediately |

| | | | | | | | |
|------------------|-------------------|--------------------------------------|------------|---------------|--------------|-----------------------|-----------------------|
| parameter | | source | | | | g | |
| | P04-02 | Digital speed given value | -6000—6000 | 0 | 1rpm | Run Settin gs | Effective immediately |
| | P04-05 | Speed alarm value | 0-6500 | 6400 | 1rpm | Run Settin gs | Effective immediately |
| | P04-06 | Forward speed limit | 0-6000 | 5000 | 1rpm | Run Settin gs | Effective immediately |
| | P04-07 | Reverse speed limit | 0-6000 | -5000 | 1rpm | Run Settin gs | Effective immediately |
| | P04-10 | Zero speed detection value | 0-200.0 | 40 | 1rpm | Run Settin gs | Effective immediately |
| | P04-14 | Speed time | 0-10000 | 500 | 1ms/100 0rpm | Run Settin gs | Effective immediately |
| P04-15 | Deceleration time | 0-10000 | 500 | Run Settin gs | | Effective immediately | |
| torque parameter | P05-10 | Internal positive torque limit value | 0-300.0 | 200.0 | 1.0% | Run Settin gs | Effective immediately |
| | P05-11 | Internal torque limit value | 0-300.0 | 200.0 | 1.0% | Run Settin gs | Effective immediately |
| I/O Parameter | P06-00 | Enable input port effective level | 0-4 | 1 | --- | Run Settin gs | Re-power |

| | | | | | | | |
|------------------------------|--------|--|---------|------|-----|--------------|-----------------------|
| | P06-20 | Alarm output port effective level | 0-1 | 1 | --- | Run Settings | Re-power |
| | P06-22 | Output port in place valid level | 0/1 | 1 | --- | Run Settings | Re-power |
| Advanced function parameters | P08-19 | low pass filter constant of Feedback speed | 0-25.00 | 0.8 | 1ms | Run Settings | Effective immediately |
| | P08-20 | Torque command filter constant | 0-25.00 | 0.84 | 1ms | Run Settings | Effective immediately |
| | P08-25 | Disturbing torque compensation gain | 0-100.0 | 0 | % | Run Settings | Effective immediately |
| | P08-26 | Disturbing torque filter time constant | 0-25.00 | 0.8 | 1ms | Run Settings | Effective immediately |

5.2 Description of parameter analysis

5.2.1 P00-xx Motor and driver parameters

| Parameter code | Name | Instruction |
|----------------|--------------------|---|
| P00-00 | Motor number | Factory set, no need to set 0: P0-01 to P0-17 play a role |
| P00-01 | Motor rated speed | Setting range : 1-6000, Unit: rpm Factory setting has done ,no need to set |
| P00-02 | Motor rated torque | Setting range: 0.01-655.35, Unit: N.M Setting according to the matched motor, factory setting has done |
| P00-03 | Rated current of | Setting range: 0.01-655.35, unit: A |

| | | |
|--------|--|---|
| | motor | According to the motor settings, the factory has been set up. |
| P00-04 | Motor moment of inertia | Setting range: 0.01-655.35, unit: kg.cm ² Setting according to the matched motor , factory setting has done |
| P00-05 | Pole number of motor | Set range: 1-31, unit: opposite pole ,Setting according to the matched motor , factory setting has done |
| P00-10 | Incremental encoder number | Setting according to the matched motor , factory setting has done |
| P00-11 | Incremental encoder Z pulse Angle | Setting according to the matched motor , factory setting has done |
| P00-12 | Initial rotor Angle 1 | Setting according to the matched motor , factory setting has done |
| P00-13 | Initial rotor Angle 2 | Setting according to the matched motor , factory setting has done |
| P00-14 | Initial rotor Angle 3 | Setting according to the matched motor , factory setting has done |
| P00-15 | Initial rotor Angle 4 | Setting according to the matched motor , factory setting has done |
| P00-16 | Initial rotor Angle 5 | Setting according to the matched motor , factory setting has done |
| P00-17 | Initial rotor Angle 6 | Setting according to the matched motor , factory setting has done |
| P00-21 | RS232Communication baud rate selection | Setting range : 0-3 Select the baud rate when communicating with PC0: 9600 1: 19200 2: 57600 3: 115200 |
| P00-23 | Slave station address | Setting range: 0—255, the default value is 1 Set up according to equipment requirements |

| | | |
|--------|---|---|
| P00-24 | Modbus Communication baud rate | Setting range : 0-7, The default value is 2 0:2400 1:4800 2:9600 3:19200 4:38400 5:57600 6:115200 7:25600 |
| P00-25 | Check way | Setting range: 0-3, default value : 1 0: no check, two stop bits 1: even check, 1 stop bit 2: odd check, 1 stop bit 3: no check, 1 stop bit |
| P00-26 | Modbus Communication response delay | Setting range: 0-100, Unit ms |
| P00-42 | Overvoltage protection threshold | Setting range: 0-300, unit V |

5.2.2 P01-xx Master control parameter

| Parameter code | name | Instruction |
|----------------|-------------------------|---|
| P01-01 | Control mode setting | Setting range: 0-6 0: position control mode 1: speed control mode 2: torque control mode |
| P01-02 | Real time automatic | 332/5000 Setting range: 0-2 |

| | | |
|--------|--|--|
| | adjustment mode | <p>0: manually adjust the rigidity.</p> <p>1: standard mode automatically adjusts rigidity. In this mode, parameters p02-00, p02-01, p02-10, p02-11, p02-13, p02-14, and p08-20 will be set automatically according to the rigidity level set by p01-03. Manual adjustment of these parameters will not work. The following parameters are set by the user: P02-03 (speed feed-forward gain), p02-04 (speed feed-forward smoothing constant).</p> <p>2: positioning mode automatically adjusts rigidity. In this mode, parameters p02-00, p02-01, p02-10, p02-11, p02-13, p02-14, and p08-20 will be set automatically according to the rigidity level set by p01-03. Manual adjustment of these parameters will not work. The following parameters will be fixed and cannot be changed: P02-03 (speed feedforward gain) : 30.0% P02-04 (speed feed-forward smoothing constant) : 0.50</p> |
| P01-03 | Adjust the rigid setting automatically in real time | <p>Setting range: 0-31</p> <p>Built-in 32 gain class parameters, when p01-02 set to 1, or 2. Can be called directly according to the actual situation, the larger the set value, the stronger the rigidity.</p> |
| P01-04 | Moment of inertia ratio | <p>Setting range: 0-100, unit: times</p> <p>Set the load inertia ratio of the corresponding motor. The setting method is as follows: P01-04= load inertia/motor moment of inertia This inertia ratio can use the value identified by AF-J-L automatic inertia identification and write the value into the parameter</p> |
| P01-30 | Brake command - servo OFF delay time (brake opening delay) | <p>Setting range: 0-255, unit: ms</p> <p>When open the Enable: after the enable instruction is executed, the drive will receive the position instruction after the time of p01-30.</p> |

| | | |
|--------|---|---|
| | | When turn off the enable when the motor is in a state of rest, the time after the energy command is executed and the holding gate is closed until the motor becomes non-energized. |
| P01-31 | Speed limit value of brake instruction output | Setting range: 0-3000 Unit RPM When the motor is in a state of rotation, the motor speed threshold when the brake output is valid. If it is lower than this threshold, the brake output command is effective; otherwise, it will wait for p01-32 time before the gate output command is effective. |
| P01-32 | Servo OFF- lock instruction wait time | Setting range: 0-255, unit: ms When the motor is in a state of rotation, the maximum waiting time for the output of the holding gate. |

5.2.3 P02-xx Gain class parameter

| Parameter code | Name | Instruction |
|----------------|-------------------------|--|
| P02-00 | Position control gain 1 | Setting range: 0-3000.0, unit: 1/S As for the proportional gain of the position loop regulator, the larger the parameter value, the higher the gain ratio, the higher the stiffness, the smaller the position tracking error and the faster the response. However, too large parameters can easily cause vibration and overshoot. This parameter is for the steady-state response. |
| P02-01 | Position control gain 2 | Setting range: 0-3000.0, unit: 1/S As for the proportional gain of the position loop regulator, the larger the parameter value, the higher the gain ratio, the higher the stiffness, the smaller the position tracking error and the faster the response. However, too large parameters can easily cause vibration and overshoot. This parameter is for dynamic response. |
| P02-03 | Speed feed | Setting range: 0-100.0, unit: 1.0% |

| | | |
|--------|---|--|
| | forward gain | The feed forward gain of the speed loop, the larger the parameter value, the smaller the system position tracking error, and the faster the response. However, if the feedforward gain is too large, the position loop of the system will be unstable, which will easily cause overshoot and shock. |
| P02-04 | Speed feedforward smoothing constant | Setting range: 0-64.00, unit: ms This parameter is used to set the speed loop feed-forward filter time constant. The larger the value, the larger the filtering effect, but at the same time the phase lag increases. |
| P02-10 | Speed proportional gain 1 | Setting range: 1.00-2000.0, unit: Hz The larger the speed proportional gain, the larger the servo stiffness, the faster the speed response, but too large is easy to generate vibration and noise. This parameter value is increased as far as possible under the condition that the system is not oscillating. This parameter is for static responses. |
| P02-11 | Speed integral constant 1 | Setting range: 1.0-1000.0, unit: ms Speed regulator integral time constant. The smaller the setting value is, the faster the integral velocity is and the higher the stiffness is. This parameter value is minimized when the system does not oscillate. This parameter is for the steady-state response. |
| P02-12 | Pseudo differential feed forward control factor 1 | Setting range: 0-100.0, unit: 1.0% When the speed loop is set to 100.0%, PI control is adopted and the dynamic response is fast. When set to 0, the velocity loop integral has obvious effect and can filter low frequency interference, but the dynamic response is slow. By adjusting this coefficient, the speed loop can have better dynamic response and increase the resistance of low frequency interference. |

| | | |
|--------|---|---|
| P02-13 | Speed proportional gain 2 | <p>Setting range: 1.00-2000.0, unit: Hz</p> <p>The larger the speed proportional gain, the larger the servo stiffness, the faster the speed response, but too large is easy to generate vibration and noise.</p> <p>This parameter value is increased as far as possible under the condition that the system is not oscillating.</p> <p>This parameter is for dynamic response.</p> |
| P02-14 | The speed integral constant 2 | <p>Setting range: 1.0-1000.0, unit: ms</p> <p>Speed regulator integral time constant. The smaller the setting value is, the faster the integral velocity is and the higher the stiffness is.</p> <p>This parameter value is minimized when the system does not oscillate.</p> <p>This parameter is for dynamic response.</p> |
| P02-15 | Pseudo differential feedforward control coefficient 2 | <p>Setting range: 0-100.0, unit: 1.0%</p> <p>When the speed loop is set to 100.0%, PI control is adopted and the dynamic response is fast. When set to 0, the velocity loop integral has obvious effect and can filter low frequency interference, but the dynamic response is slow.</p> <p>By adjusting this coefficient, the speed loop can have better dynamic response and increase the resistance of low frequency interference.</p> |
| P02-19 | Torque feed forward gain | <p>Setting range: 0-30000, unit: 1.0%</p> <p>Set the weighting value of current loop feedforward. The parameter adds the current loop after weighting the differential of the speed instruction</p> |
| P02-20 | Torque feed forward smoothing constant | <p>Setting range: 0-64.00, unit: ms</p> <p>This parameter is used to set the torque feed forward filter time constant.</p> |

| | | | | |
|--------|---------------------|---|--------------------------------------|--|
| P02-30 | Gain switching mode | Setting range: 0-10 Set the first and second gain switching conditions | | |
| | | Value | Switching conditions | Remark |
| | | 0 | Fixed for the first gain | P02-00、P02-10、P02-11、P02-12 |
| | | 1 | Fixed for the second gain | P02-01、P02-13、P02-14、P02-15 |
| | | 2 | use DI input switching | Need to set the DI port to 9 (gain switching input) Invalid: first gain Effective: second gain |
| | | 3 | Torque command is big | Switch to second gain when the torque instruction is greater than the threshold(determined by P02-31 and P02-32). Less than the threshold and when it exceeds the P02-33 delay setting, switch to the first gain. |
| | | 4 | The speed instruction changes a lot. | Switches to the second gain when the speed instruction changes more than the threshold(determined by P02-31 and P02-32). Less than the threshold and when it exceeds the P02-33 delay setting, switch to the first gain. |
| | | 5 | speed command | Switch to second gain when the speed instruction is greater than the |

| | | | | |
|--|--|----|---------------------------------|---|
| | | | is large. | threshold(determined by P02-31 and P02-32). Switch to first gain when less than threshold, while exceeding P02-33 latency settings |
| | | 6 | Large position deviation | Switch to second gain when the position deviation is greater than the threshold(determined by P02-31 and P02-32). Less than the threshold and when it exceeds the P02-33 delay setting, switch to the first gain. |
| | | 7 | Have Location command. | Switch to second gain when there is a position command. The position command ends and when it exceeds the P02-33 delay setting, switch to the first gain. |
| | | 8 | Location incomplete. | Switch to second gain when positioning is not complete. Location complete, while exceeding the P02-33 delay setting, switch to first gain |
| | | 9 | Real speed is big | Switches to the second gain when the actual speed is greater than the threshold(determined by P02-31 and P02-32). Less than the threshold and when it exceeds the P02-33 delay setting, switch to the first gain. |
| | | 10 | Location command + actual speed | Switch to second gain when there is a position command. There is no position instruction and the actual speed is less than the threshold(determined by P02-31 and P02-32), and when the P02-33 delay |

| | | | | |
|--------|-------------------------------------|--|--|--|
| | | | | setting is exceeded, switch to the first gain. |
| P02-31 | Gain switching level | Set range: 0-20000 Judgment threshold for gain switching. Torque unit: 1000 bit = 25 % rated torque Speed unit: 1000 bit = 200 rpm Location Unit: 131072 bit per lap | | |
| P02-32 | Gain switching hysteresis | Set range: 0-20000 The hysteresis level during gain switching Torque unit: 1000 bit = 25 % rated torque Speed unit: 1000 bit = 200 rpm Location Unit: 131072 bit per lap | | |
| P02-33 | Gain switching delay | Set range: 0-1000 .0, unit: MS When switching from the second gain to the first gain, the time from the trigger condition to the actual switch is satisfied. | | |
| P02-34 | Position gain switching time | Set range : 0-1000.0, Unit: ms Position Control Gain 1 Smooth Switch to Position Control Gain 2 | | |
| P02-41 | Mode Switch Level | Set range: 0-20000 Set the threshold for switching. Torque unit: 1000 bit = 25 % rated torque Speed unit: 1000 bit = 200 rpm Location Unit: 131072 bit per lap | | |
| P02-50 | Torque instruction plus calculation | Set range: -100.0-100, Unit 1.0 % Location control mode is valid. This value is superimposed on a given torque value and is used for static torque compensation of the vertical axis. | | |
| P02-51 | Forward torque compensation | Set range: -100.0-100 .,Unit1.0 % Location control mode is valid. Used to compensate for forward static friction | | |
| P02-52 | Reverse torque | Set range: -100.0-100 .0, Unit 1.0 % | | |

| | | |
|--|--------------|--|
| | compensation | Location control mode is valid. Used to compensate for reverse static friction |
|--|--------------|--|

5.2.4 P03-xx Position parameters

| Parameter code | name | Instruction |
|----------------|---|--|
| P03-00 | Location Command Source | 0: Pulse command 1: Numbers given, used for communication control. |
| P03-03 | Inverse command pulse | Used to adjust pulse count direction 0: Normal. 1: Reverse direction |
| P03-04 | Location Pulse Filter Settings | Setting range : 0-3, UNIT: us 0: 0.1us. 1: 0.4us 2: 0.8us. 3: 1.6us |
| P03-05 | Location complete judgment conditions | 0: Output when position deviation is less than P03-06 setting 1: The position is given and the position deviation is less than the P03-06 setting output 2: Location given(filtered), and position deviation less than P03-06 set output |
| P03-06 | Location complete range | Set range: 0-65535, units: encoder units Use to set the threshold value for positioning completion output. Using the incremental encoder motor, the number of encoder lines * 4 per loop is calculated. |
| P03-09 | Number of command pulses for 1 motor rotation | Set range: 0-65535 Used to set the number of command pulses for the motor to rotate around. When this parameter is set to 0, the P03-10 and P03-11 parameters are valid. |

| | | |
|------------|---|---|
| P03-1 0 | Molecular of electronic gear 1 | The formula for calculating the electronic gear ratio of $G = \frac{\text{Incremental Encoder line quantity}}{\text{Motor C: Line of coder}} = \frac{P}{C \times 4}$ eg.: Encoder line quantity 2500; Input pulse quantity error rate 3200; Electronic gear ratio of Motors: $C: \frac{2500 \times 4}{10000} = \frac{P}{25}$ $G = \frac{2500}{3200} = \frac{25}{3200} = \frac{1}{128}$ |
| P03-1 1 | The denominator of electronic gear 1 | Remark |
| P03-1 5 | Position deviation too large setting | Setting range: 0-65535, unit: instruction unit *10 Set the number of pulses that are allowed to deviate it will alarm if beyond the set value. Example: set value is 20. When the following deviation exceeds 20*10, the driver will alarm AL.501 (the position deviation is too large). |
| P03-1 6 | Position command smoothing constant | Setting range: 1000, unit: ms Set the time constant of the position instruction smoothing filter |

5.2.5 P04-xx Speed parameter

| Parameter code | name | Instruction |
|----------------|------------------------------|---|
| P04-0 0 | Speed command source | 0: external analog instruction 1: digital instruction (parameter setting) 2: digital instruction (communication) 3: internal multiple sets of instructions |
| P04-0 2 | Digital speed given value | Set range: -6000-6000, units: rpm When P04-00 is set to 1, P04-02 is the speed control setting value |
| P04-0 5 | Overspeed alarm value | Set range: 0-6500, unit: rpm Set allowed maximum speed, exceeding set value will A.420 |

| | | |
|------------|-------------------------------|--|
| | | speed alarm |
| P04-0 6 | Forward speed limit | Set range: 0-6000 in rpm Limit motor forward speed |
| P04-0 7 | Reverse speed limit | Set range: 0-6000 in rpm Limit motor reverse speed |
| P04-1 0 | Zero speed detection value | Set range: 0-200 .0 in rpm Set the zero speed exit limit, the motor speed below the threshold can output the "motor zero speed output" signal through the output port |
| P04-1 4 | acceleration time | Setting range: 0-10000, unit: 1ms/1000rpm Set the acceleration for speed control |
| P04-1 5 | Deceleration time | Setting range: 0-10000, unit: 1ms/1000rpm Set the deceleration speed for speed control |

5.2.6 P05-xx Torque parameters

| Para meter code | name | Instruction |
|--------------------------------|---|--|
| P05-1 0 | Internal positive torque limit value | Setting range: 0-300.0, unit: 1.0% The forward output of the motor is limited, with 100 denoting 1 times torque and 300 denoting 3 times torque When the torque output reaches the limit value, the output signal can be detected by the torque limit output on the DO port |
| P05-1 1 | Internal torque limit value | Setting range: 0-300.0, unit: 1.0% Limited motor output, 100 represents 1 times torque, 300 represents 3 times torque When the torque output reaches the limit value, the output signal can be detected by the torque limit output on the DO port |

5.2.7 P06-xx I/O Parameter

| Parameter code | Name | Instruction |
|----------------|--|--|
| P06-00 | Enable the output port to be effectively level | Setting range: 0-1, factory setting: 1 |
| P06-20 | Alarm output port effective level | Setting range: 0-1, factory setting: 1 |
| P06-22 | Put in place the output port effective level | Setting range: 0-1, factory setting: 1 |

5.2.8 P08-xx Advanced function parameters

| Parameter code | Name | Instruction |
|----------------|--|--|
| P08-19 | Feedback speed low-pass filtering constant | Setting range: 0-25.00, unit: ms The feedback speed low-pass filter time constant can be set to large when the motor is roaring during operation. |
| P08-20 | Torque command filter constant | Setting range: 0-25.00, unit: ms Torque instruction filter time constant, when the motor running in the squealing, the value can be appropriately set to large. |
| P08-25 | Disturbance torque compensation gain | Setting range: 0-100.0 Gain coefficient of perturbation torque observation. The higher the value, the stronger the anti-disturbance torque capacity, but the motion noise may also increase. |
| P08-26 | The perturbation torque filter time constant | Setting range: 0-25.00, unit: ms The larger the value, the stronger the filtering effect, can inhibit the motion noise. However, the effect of disturbance torque is affected by the phase delay. |

5.3 Monitor project list

| displaying | Display item | Description | Unit |
|------------|--------------|-------------|------|
|------------|--------------|-------------|------|

| | | | |
|---------------|---|--|------------------------------------|
| serial number | | | |
| d00.C.PU | The sum of the position commands | This parameter can monitor the number of pulses sent by the user to the servo driver, so as to confirm whether any pulse loss occurs | Instruction unit |
| d01.F.PU | The sum of the position feedback pulses | This parameter can monitor the pulse number of the servo motor feedback. The unit is the same as the user input unit | Instruction unit |
| d02.E.PU | Number of position deviation pulses | This parameter can monitor the pulse number of position delay in the operation of the servo system. The unit is the same as the user input unit | Instruction unit |
| d03.C.PE | The position is given the sum of the pulses / Feedback pulse of gantry motor | This parameter can monitor the number of pulses sent by the user to the servo driver. Unit: when using absolute value motor, calculate at 131072bit for each turn. With the incremental encoder motor, the number of encoder lines per lap is *4. | Encoder unit/ Instruction unit |
| d04.F.PE | Position feedback pulse sum | This parameter can monitor the pulse number of the servo motor feedback. Unit: when using absolute value motor, calculate at 131072bit for each turn. With the incremental encoder motor, the number of encoder lines per lap is *4. | Encoder unit / Instruction unit |
| d05.E.PE | Position deviation pulse number /Gantry pulse deviation | This parameter can monitor the pulse number of position delay in the operation of the servo system. Unit: when using absolute value motor, calculate at 131072bit for each turn. With the incremental encoder motor, the number of | Encoder unit/ Instruction unit |

| | | | |
|-----------|-------------------------------|---|---------------|
| | | encoder lines per lap is *4. | |
| d06.C.Fr | Pulse command input frequency | This parameter can monitor the input frequency of external pulse instruction | KPPS |
| d07.C.SP | Speed control instruction | | rpm |
| d08.F.SP | Motor speed | This parameter can monitor the speed when the servo motor is running | rpm |
| d09. C.tQ | Torque command | This parameter can monitor the torque when the servo motor is running | % |
| d10. F.tQ | Torque feedback value | This parameter can monitor the torque feedback when the servo motor is running | % |
| d11.AG.L | The average torque | This parameter can monitor the servo motor's average torque for the past 10 seconds | % |
| d12.PE.L | Peak torque | This parameter can monitor the peak torque of the servo motor after power on | % |
| d13.oL | Overload load rate | This parameter can monitor the load occupancy of the servo motor for the past 10 seconds | % |
| d14.rG | Regenerative load factor | This parameter can monitor the load rate of regenerative resistance | % |
| d16.I.Io | Input IO state | This parameter can monitor the input port state of CN1. The upper vertical bar represents the high level (optocoupler cutoff), and the lower horizontal bar represents the low electro-optical coupling conduction). The corresponding relation with the input port is that the operation panel corresponds to di1-di4 from right to left | binary system |
| d17.o.Io | Output IO state | This parameter can monitor the output port state of CN1. The upper vertical bar represents the optical coupling lead, while the | binary system |

| | | | |
|----------|--|---|-------------------|
| | | lower vertical bar represents the optical coupling cut-off. The corresponding relation with the output port is that the operation panel corresponds to do1-do3 from right to left | |
| d18.AnG | Machine Angle | This parameter can monitor the motor mechanical Angle, rotation 1 turn is 360 degrees | 0.1degree |
| d19.HAL | Motor UVW phase sequence | This parameter can monitor the phase sequence position of the incremental encoder motor | |
| d20.ASS | Absolute value encoder single coil number | This parameter can monitor the feedback value of the absolute encoder, rotating one circle as 0xffff | 0-0xFFFF |
| d21.ASH | 10/5000 Absolute value encoder multi-turn numerical value | This parameter can be used to monitor the number of turns of the absolute multi-coil encoder motor | |
| d22.J-L | Inertia ratio | This parameter can monitor the real-time inertia of the motor load | % |
| d23.dcp | Main circuit voltage (dc value) | This parameter can monitor the voltage value of the main circuit | V |
| d24.Ath | Driver temperature | This parameter can monitor drive temperature | degree centigrade |
| d25.tiE | Cumulative running time | This parameter can monitor the drive run time in seconds | Second |
| d26.1.Fr | Resonance frequency 1 | This parameter can monitor the resonant frequency 1 | Hz |
| d28.2.Fr | Resonance frequency 2 | This parameter can monitor the resonant frequency 2 | Hz |
| d30.Ai1 | Analog quantity | This parameter can monitor the speed loop's | 0.01V |

| | | | |
|---------|---|--|-------|
| | command 1 input voltage (V_REF) | analog instruction (v-ref) input voltage value. | |
| d31.Ai2 | Analog quantity command 2 input voltage (T_REF) | This parameter can monitor the input voltage value of the analog instruction (t-ref) of the torque loop. | 0.01V |

6 、 Fault analysis and treatment

6.1 Fault alarm information table

| Alarm type | The serial number code | Alarm content |
|--------------------|---|---|
| A hardware failure | AL.051 | EEPROM parameter anomaly |
| | AL.052 | Programmable logic configuration failures |
| | AL.053 | Initialization failed |
| | AL.054 | A system exception |
| | AL.060 | Product model selection fault |
| | AL.061 | Product matching fault |
| | AL.062 | Parameter storage failure |
| | AL.063 | Overcurrent detection |
| | AL.064 | The servo self - check found the output to ground short circuit fault |
| | AL.066 | Servo unit control power supply low |
| | AL.070 | AD sampling fault 1 |
| | AL.071 | Current sampling fault |
| | AL.100 | Parameter combination anomaly |
| | AL.101 | AI setting fault |
| | AL.102 | DI distribution fault |
| | AL.103 | DO allocation fault |
| | AL.105 | Error setting of electronic gear |
| AL.106 | Abnormal output setting of frequency division pulse | |
| AL.110 | The parameters should be reset | |

| | | |
|---------------|--------|---|
| | AL.120 | Invalid alert for servon command |
| | AL.401 | Under voltage |
| | AL.402 | Over voltage |
| | AL.410 | Overload (instantaneous maximum load) |
| | AL.411 | Driver overload |
| | AL.412 | Motor overload (maximum continuous load) |
| | AL.420 | Over speed |
| | AL.421 | Out of control check out |
| | AL.422 | Speed fault |
| | AL.425 | AI sampling voltage is too high |
| | AL.435 | Impulse current limits resistance overload |
| | AL.436 | DBoverload |
| | AL.440 | Radiator overheating |
| | AL.441 | Motor overheat fault |
| | AL.500 | Frequency division pulse output overspeed |
| | AL.501 | Excessive deviation of position |
| | AL.502 | Full closed - loop encoder location and motor location deviation is too large |
| | AL.505 | P command input pulse exception |
| | AL.550 | Failure identification of inertia |
| | AL.551 | Return to origin timeout fault |
| | AL.552 | Angle to identify failed faults |
| Encoder fault | AL.600 | Short circuit fault of encoder output power |
| | AL.610 | Incremental decoder offline |
| | AL.611 | Incremental encoder Z signal loss |
| | AL.620 | Bus type encoder off line |
| | AL.621 | Read/write motor encoder EEPROM parameter abnormal |
| | AL.622 | Motor encoder EEPROM data verification error |
| Warning | AL.900 | Excessive deviation of position |
| | AL.901 | The position deviation of the servo ON is too large |
| | AL.910 | Motor overload |

| | | |
|--|--------|---|
| | AL.912 | Driver overload |
| | AL.941 | Parameter changes that require reconnection |
| | AL.942 | Write EEPROM frequent warning |
| | AL.943 | Serial communication exception |
| | AL.950 | Overpass warning |
| | AL.971 | Undervoltage warning |

6.2 Fault alarm reason and disposal

AL.051: EEPROMparameter anomaly

| Fault alarm reason | Fault alarm check | Treatment measure |
|------------------------------|-------------------|--|
| Server EEPROM data exception | Check the wiring | Correct wiring and recharge If always present, change the drive |

AL.053: Failure to initialize

| Fault alarm reason | Fault alarm check | Treatment measure |
|--|---|-------------------------------------|
| Main control failed to initiate power on MCU | Check the wiring Back to electricity | If always present, change the drive |

AL.063: Overcurrent detection

| Fault alarm reason | Fault alarm check | Treatment measure |
|--|--|---|
| The power module of servo unit has excessive current | Is there a short circuit in U,V,W connection Is there a short circuit between B1 and B3 | Correct connection If always present, change the drive |

AL.071: Current sampling fault

| Fault alarm reason | Fault alarm check | Treatment measure |
|--|---------------------------|---|
| Abnormal sampling data of current sensor | Is the connection correct | Correct connection If always present, change the drive |

AL.100: Parameter combination anomaly

| Fault alarm reason | Fault alarm check | Treatment measure |
|-------------------------|--------------------------|------------------------------|
| Parameter setting error | Check the parameters set | Set the parameters correctly |

| | | |
|--|----------|---|
| | (p03-07) | If always occurs, do parameter initialization |
|--|----------|---|

AL.102: DIistribution of the fault

| Fault alarm reason | Fault alarm check | Treatment measure |
|---|--|--|
| At least two input ports have the same function selection | Check port input function to select parameters | Set the parameters correctly The drive is reenergized |

AL.103: DO Distribution of the fault

| Fault alarm reason | Fault alarm check | Treatment measure |
|---|---|--|
| At least two output ports have the same function selection parameters | Check port output function to select parameters | Set the parameters correctly The drive is reenergized |

AL.105: Electronic gear setting error

| Fault alarm reason | Fault alarm check | Treatment measure |
|---|--|--|
| Error setting of electronic gear ratio | Check the setting parameters of the electronic gear ratio.P03-10,P03-11 | Set the electronic gear ratio correctly |
| The output pulse of the gantry is set too small | Check the number of feedback pulses for one rotation of the gantry motor: p03-52 must be larger than 128 | Correctly set the number of feedback pulses for the rotation of one function motor in Longmen. |

AL.110: The parameters should be reset

| Fault alarm reason | Fault alarm check | Treatment measure |
|---|---------------------|---------------------|
| After setting the servo parameters, it needs to be reenergized to take effect | Re-power the driver | Re-power the driver |

AL.401: Under voltage

| Fault alarm reason | Fault alarm check | Treatment measure |
|---|--|--|
| The input voltage of the main circuit is lower than the rated voltage or no input voltage | Check whether the input wiring of the main loop is correct and what voltage is | Ensure correct wiring and use the correct voltage source or series connection stabilizer |

| | | |
|--|--|--|
| | | |
|--|--|--|

AL.402: Over voltage

| Fault alarm reason | Fault alarm check | Treatment measure |
|---|--|--|
| The input voltage of the main circuit is higher than the rated voltage | Use the voltmeter to test whether the input voltage of the main circuit is correct | Use the correct voltage source or serial voltage stabilizer |
| Driver hardware fault | When it is determined that the input voltage is correct, the alarm is still over voltage | Please send it back to the dealer or the original factory for inspection |
| The regenerative resistance is not connected or the regenerative resistance is not selected correctly | Verify that p00-30 is set to 0 or 1 | Correct setting and external regenerative resistance |

AL.410: Overload (instantaneous maximum load)

| Fault alarm reason | Fault alarm check | Treatment measure |
|--|---|--|
| The machine is stuck when the motor starts | Check if mechanical connections are stuck | Adjust mechanical structure |
| Driver hardware failure | Verify that the mechanical part is normal and still alarm | Please send it back to the dealer or the original factory for inspection |

AL.412: Motor overload (continuous maximum load)

| Fault alarm reason | Fault alarm check | Treatment measure |
|--|---|---|
| Use continuously beyond the rated load of the driver | It can be monitored through d13.ol in the monitoring mode | Change the motor or reduce the load |
| Improper parameter setting of control system | <ol style="list-style-type: none"> Whether the mechanical system is installed The acceleration setting constant is too fast Whether the gain class | <ol style="list-style-type: none"> Adjust the control loop gain Set time for acceleration and deceleration to slow down |

| | | |
|--------------------|------------------------------|--------------------|
| | parameters are set correctly | |
| Motor wiring error | Check U, V, W connection | Correct connection |

AL.420: Over speed

| Fault alarm cause | Fault alarm check | The disposal measures |
|---|--|--|
| The input speed command is too high | Use a signal detector to check if the input signal is normal | Adjust the frequency of the input signal |
| Incorrect parameter setting for overspeed determination | Check whether p04-05 (speed alarm value) is set properly | Set p04-05 correctly (alarm value for overspeed) |

AL.440: Radiator overheating

| Fault alarm cause | Fault alarm check | treatment measure |
|--|---|---|
| Drive internal temperature higher than 95 °C | Check the heat dissipation condition of the drive | Improve the heat dissipation condition of the drive. If the alarm occurs again, please send the drive back to the original factory for inspection |

AL.501: Position error is too big

| Fault alarm reason | Fault alarm check | The disposal measures |
|--|---|---|
| The location deviation is too large and the parameter setting is too small | Confirm the parameter setting of p03-15 (location deviation is too large) | Increase the p03-15 (position deviation is too large) setting value |
| The gain is set too small | Verify that the gain class parameters are set properly | Reset the gain class parameters correctly |
| Internal torque limit setting is too small | Confirm the internal torque limit value | Adjust the internal torque limit value correctly |
| Excessive external load | Check external load | Reduce load or replace power motor |

AL.505: P Command input pulse exception

| Fault alarm reason | Fault alarm check | The disposal measures |
|--|---|---|
| The pulse command frequency is higher than the | The pulse frequency meter is used to detect whether the | Set the input pulse frequency correctly |

| | | |
|-----------------------|--|--|
| rated input frequency | input frequency is higher than the rated input frequency | |
|-----------------------|--|--|

AL.610: Incremental decoder offline

| Fault alarm reason | Fault alarm check | The disposal measures |
|--|--------------------------|-----------------------|
| Incremental encoder HallU, HallV, HallW signal anomaly | Check the encoder wiring | correct wiring |

AL943: 6/5000

Serial communication exception

| Fault alarm reason | Fault alarm check | The disposal measures |
|---|---|--|
| Serial communication interference The baud rate of serial port is set too high | Check the wiring Check the baud rate parameter p00-21 for serial communication | Add a filter to the wire Reduce the baud rate of serial communication |

7、Control signal connection

7.1 Control signal single terminal common anode connection

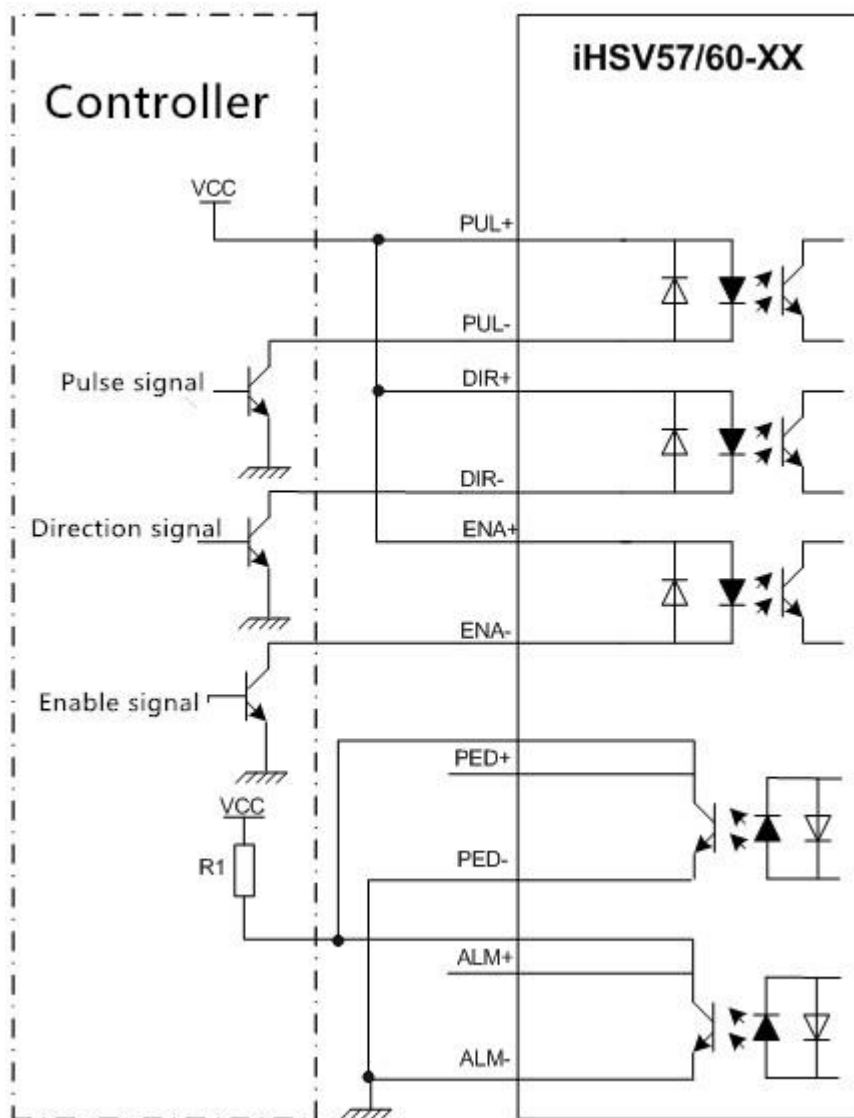

Note:

VCC is compatible with 5V~24V.

The resistance R1 is connected to the control signal terminal, and the resistance value is 3~5K.

7.2 Control signal single terminal common cathode connection

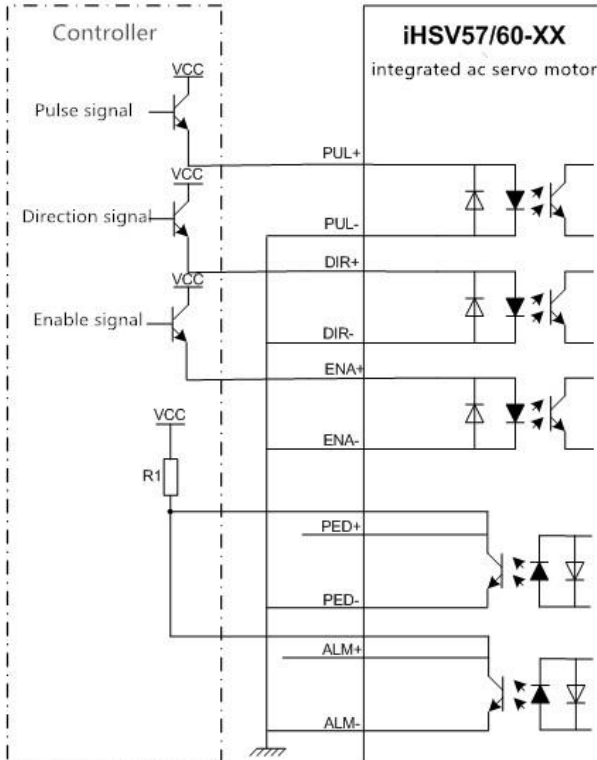

Note:

VCC is compatible with 5V~24V.

The resistance R1 is connected to the control signal terminal, and the resistance value is 3~5K.

7.3 Control signal differential connection mode

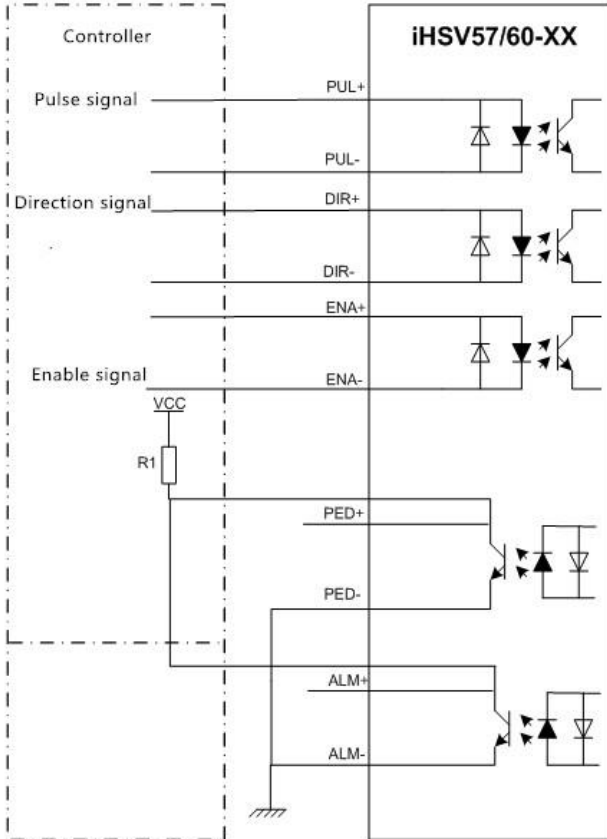

Note: VCC is compatible with 5V~24V. The resistance R1 is connected to the control signal terminal, and the resistance value is 3~5K.

7.4 232 Serial communication wiring diagram

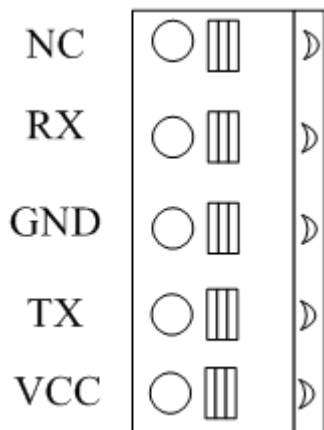

| Definition | Description | Color connection for 232 serial communication lines |
|------------|-----------------|---|
| NC | hang in the air | |
| RX | receiving end | Brown and white |
| GND | Power- | Blue |
| TX | The sender | Blue and white |
| VCC | Power + | |

7.5 Control signal sequence diagram

In order to avoid some wrong actions and deviations, PUL, DIR and ENA should meet certain requirements, as shown in the figure below:

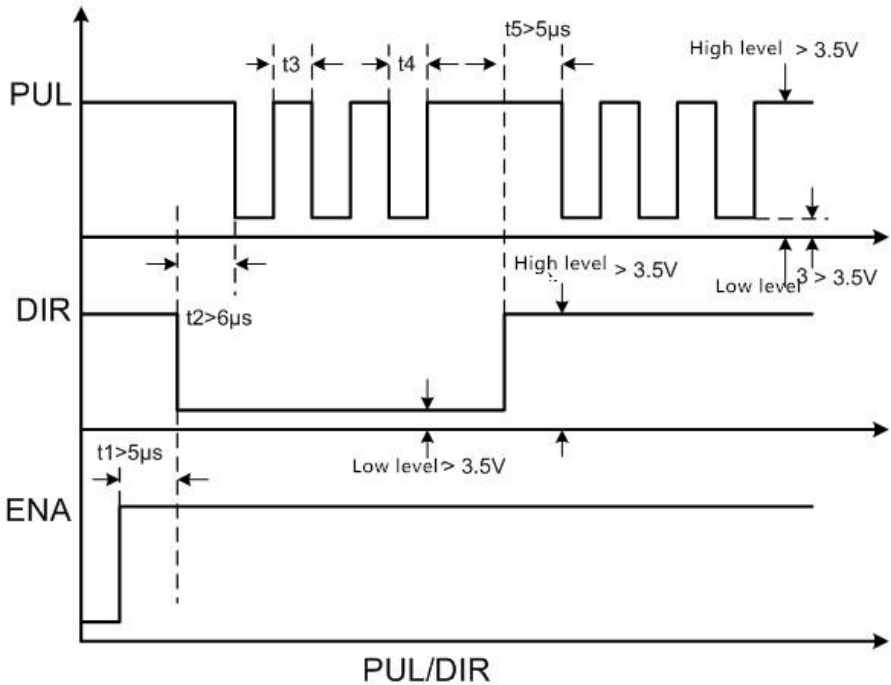

Remark:

- (1) t_1 : ENA (enabling signal) should be at least 5 μs ahead of time, which is determined to be high. It is generally recommended that ENA+ and ENA- be suspended.
- (2) t_2 : DIR at least predates the PUL count edge 6, indicating that the state is high or low.
- (3) t_3 : the pulse width shall not be less than 2.5 μs .
- (4) t_4 : the width of low level is not less than 2.5 μs .

7.6 Servo motor speed torque characteristic curve

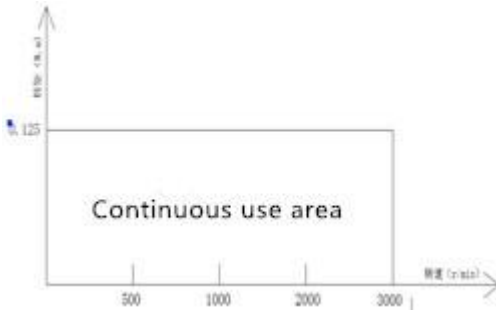

iHSV42-40-05-24-XXX4/5000 Torque characteristics

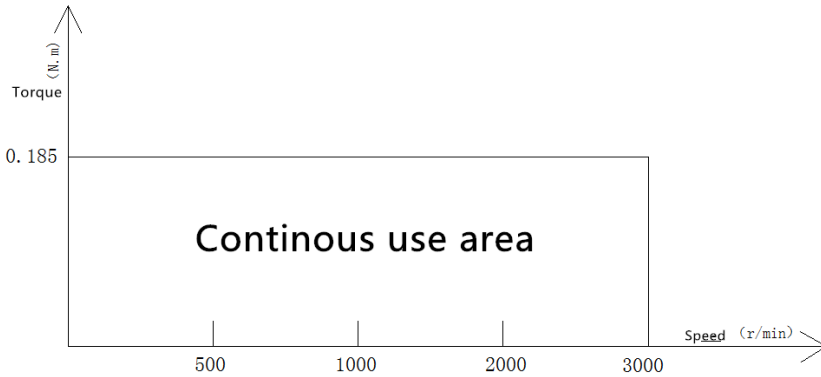

iHSV42-40-07-24-XXX4/5000 Torque characteristics

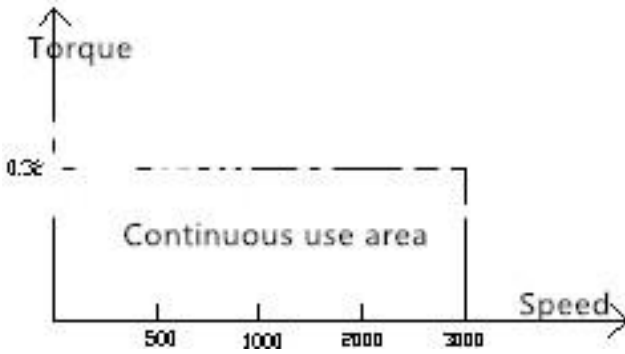

iHSV57-30-10-36-XXX4/5000 Torque characteristics

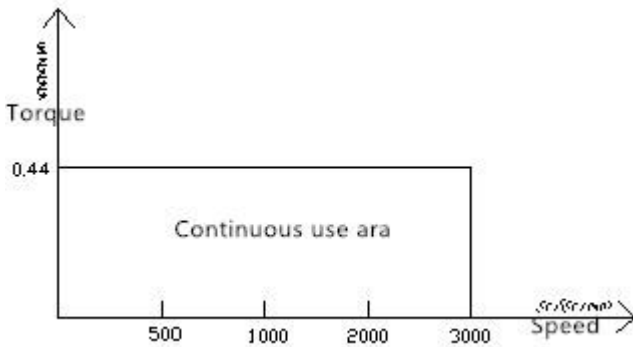

iHSV57-30-14-36-XXX4/5000 Torque characteristics

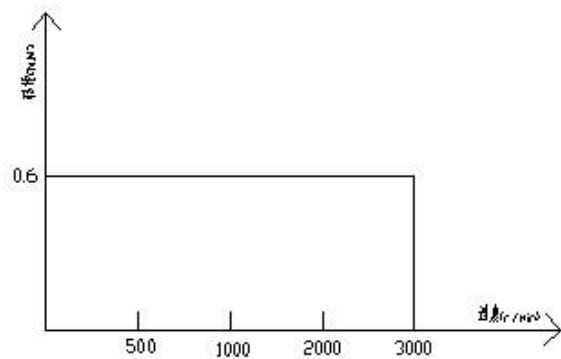

iHSV57-30-18-36-XXX4/5000 Torque characteristics

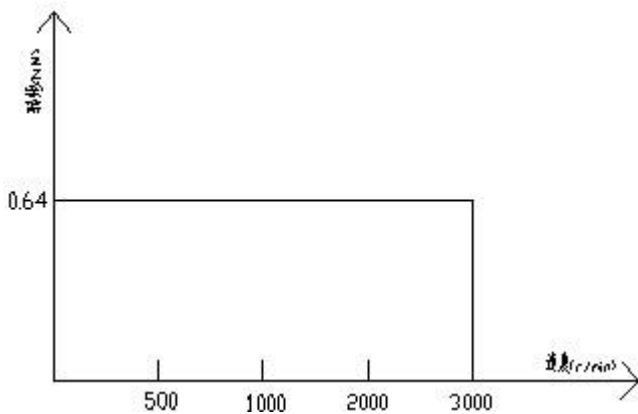

iHSV60-30-20-36-XXX4/5000 Torque characteristics

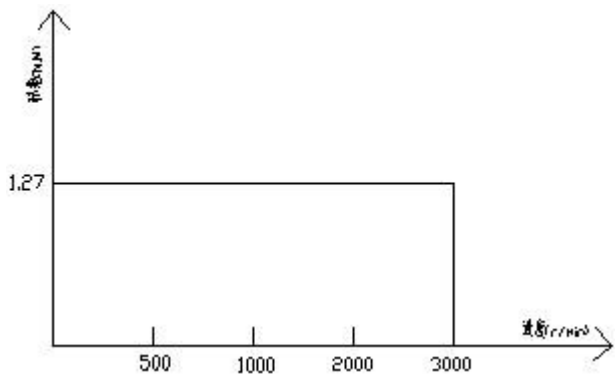

iHSV60-30-40-48-XXX4/5000 Torque characteristics

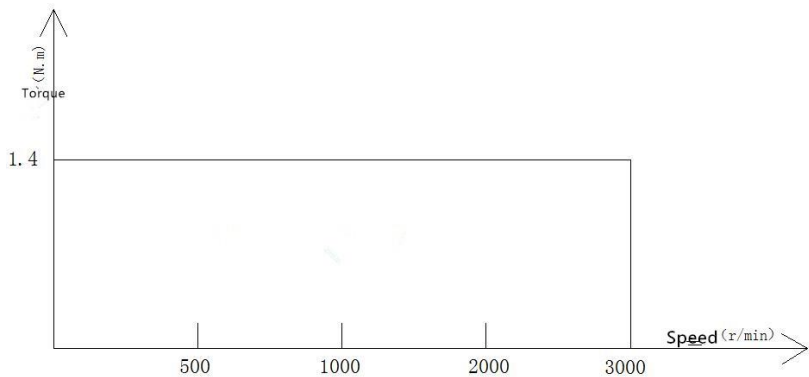

iHSV86-30-44-48-XXX4/5000 Torque characteristics

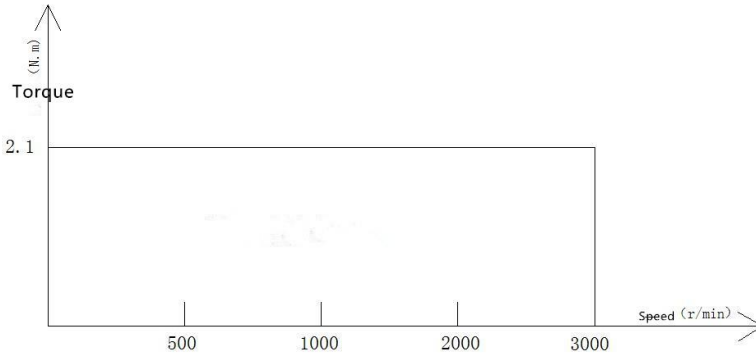

iHSV86-30-66-72-XXX4/5000 Torque characteristics

8.Setting of dial code for subdivision

8.1Subdivision Settings

The subdivision Settings are as follows: when SW1, SW2, SW3 and SW4 are all set as on, the user's customized subdivision is effective, and this value can be set by our company's servo software.

| Drawing codes switch Subdivision | SW1 | SW2 | SW3 | SW4 |
|--|-----|-----|-----|-----|
| Default | on | on | on | on |
| 800 | off | on | on | on |
| 1600 | on | off | on | on |
| 3200 | off | off | on | on |
| 6400 | on | on | off | on |
| 12800 | off | on | off | on |
| 25600 | on | off | off | on |
| 51200 | off | off | off | on |
| 1000 | on | on | on | off |

| | | | | |
|-------|-----|-----|-----|-----|
| 2000 | off | on | on | off |
| 4000 | on | off | on | off |
| 5000 | off | off | on | off |
| 8000 | on | on | off | off |
| 10000 | off | on | off | off |
| 20000 | on | off | off | off |
| 40000 | off | off | off | off |

8.2 Input edge Settings

SW5 dial code switch sets input edge, off means rising edge and on means falling edge.

8.3 Logical direction setting

When SW6 dial code switch off or on, the direction of current motor motion can be changed, off = CCW (forward), on=CW (reverse).

9、 Error alarm and LED flashing frequency

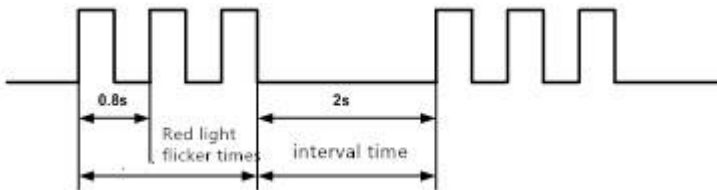

| Number of red light flashes | Alarm Description | Treatment measures |
|-----------------------------|--|---|
| 2 | Driver overcurrent | Is there a short circuit in the motor UVW line |
| 3 | Drive position deviation exceeds set value | Check if driver "deviation in place" parameter is set correctly |
| 4 | Drive encoder alarm | Check whether the encoder wire is properly connected |
| 7 | Driver overload | Check whether the motor UVW wire is connected correctly |

10. Installation Dimensions

Mounting dimensions (unit: mm)

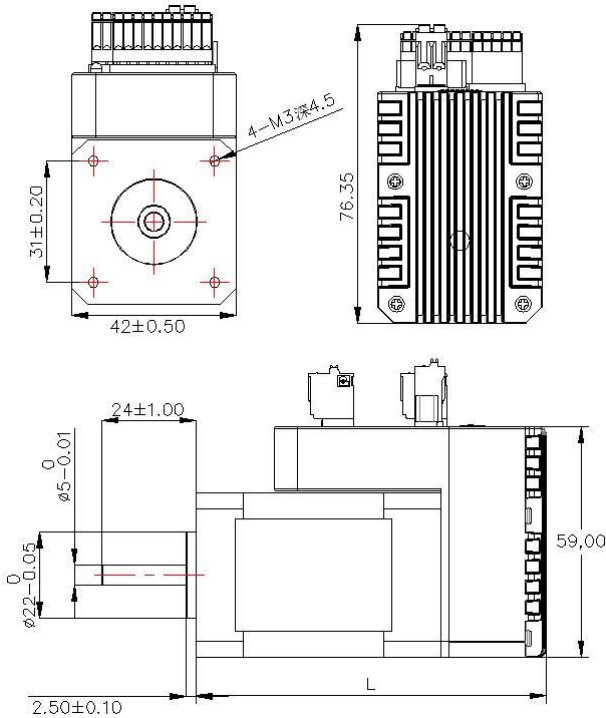

IHSV42-XX Mounting dimensions

| Model | Length L (mm) | shaft (mm) |
|---------------------|---------------|------------|
| iHSV42-40-05-24-XXX | 84 | 24 |
| iHSV42-40-07-24-XXX | 110 | |

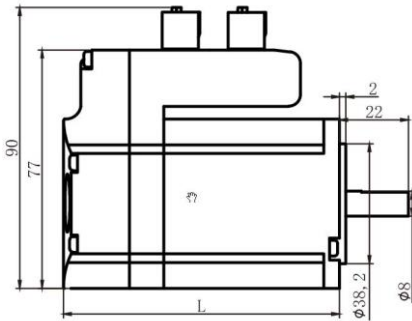
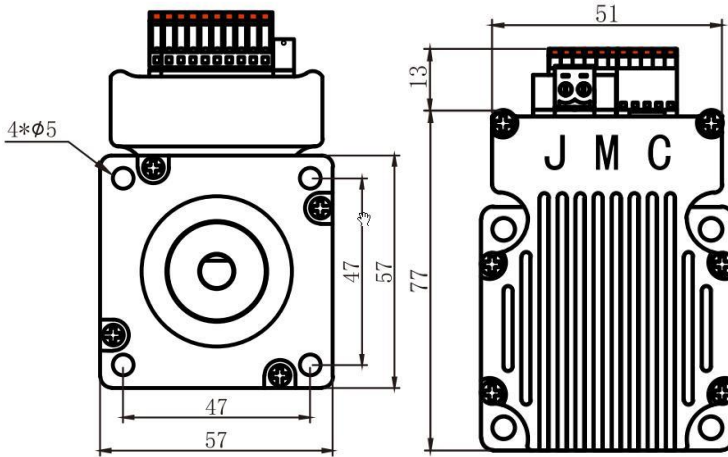

iHSV57-XX Mounting dimensions

| Model No. | Length L (mm) | shaft (mm) |
|-----------------------------|---------------|------------|
| iHSV57-30-10-36-01-T-33-XXX | 110 | 33 |
| iHSV57-30-14-36-01-T-33-XXX | 130 | |
| iHSV57-30-18-36-01-T-33-XXX | 150 | |

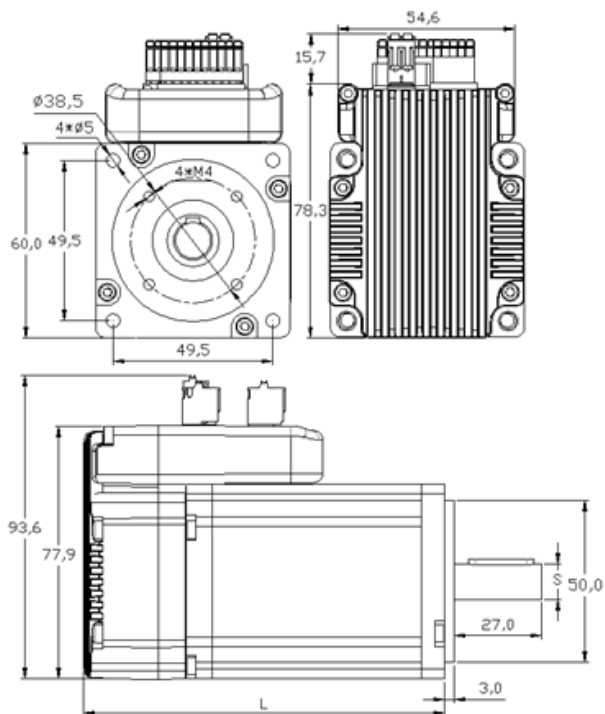

iHSV60-XX Mounting dimensions

| Model No. | Length L (mm) | diameter of Shaft S(mm) | Shaft length (mm) |
|------------------------|---------------|-------------------------|-------------------|
| iHSV60-30-20-36-XXX | 110 | 11 | 30 |
| iHSV60-30-20-36-03-XXX | 130 | 14 | |
| iHSV60-30-40-36-XXX | 110 | 14 | |

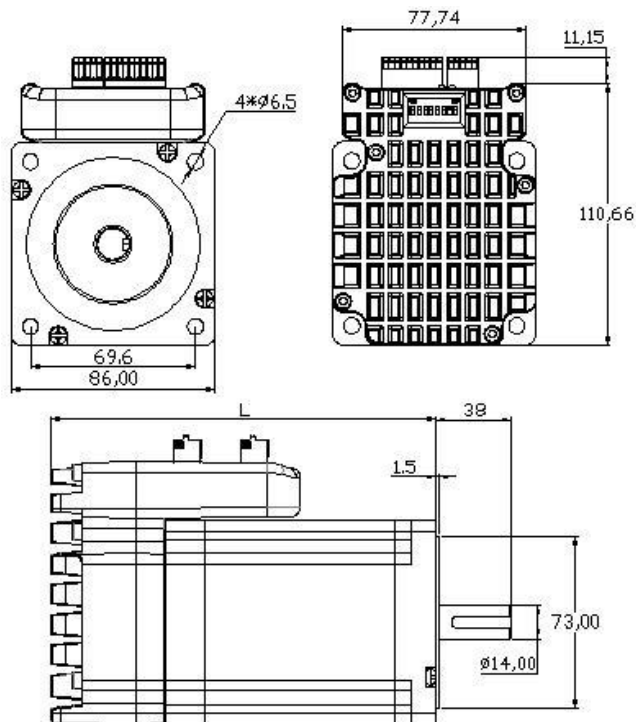

iHSV86-XX Mounting dimensions

| Model | Lenght L (mm) | Shaft (mm) |
|---------------------|---------------|------------|
| iHSV86-30-44-48-XXX | 162 | 38 |
| iHSV86-30-66-72-XXX | 189 | |

11、RFQ and analysis

11.1 Power lamp is not on

Check whether the power supply has input and whether the line connection is correct.

Whether the input voltage is too low.

High input voltage will burn out the servo drive motor。

11.2 power on the red light to alarm

Whether the input voltage of servo drive motor is too high or too low.

Whether the servo drive motor has pulse input all the time before power on, resulting in overshoot alarm.

11.3 Run a small Angle of rotation after the red light alarm

In the configuration parameters of the servo drive motor, whether the pole logarithm of the motor and the number of lines of the encoder are matched (the pole logarithm is: 4, and the number of lines of the encoder is: 1000).

If the pulse input speed is greater than the motor's rated speed, the position is out of tolerance.

11.4 the pulse does not rotate after input

Whether the connection of the pulse input terminal of the servo drive motor is reliable.

Whether the servo drive motor can be released, whether the energy signal has input.

The electronic gear ratio is too large.

12、iHSV42/57/60/86-XX Parameter modification steps

1、Choose JmcServoPcControl Servo adjust software, Double-click to open the following image:

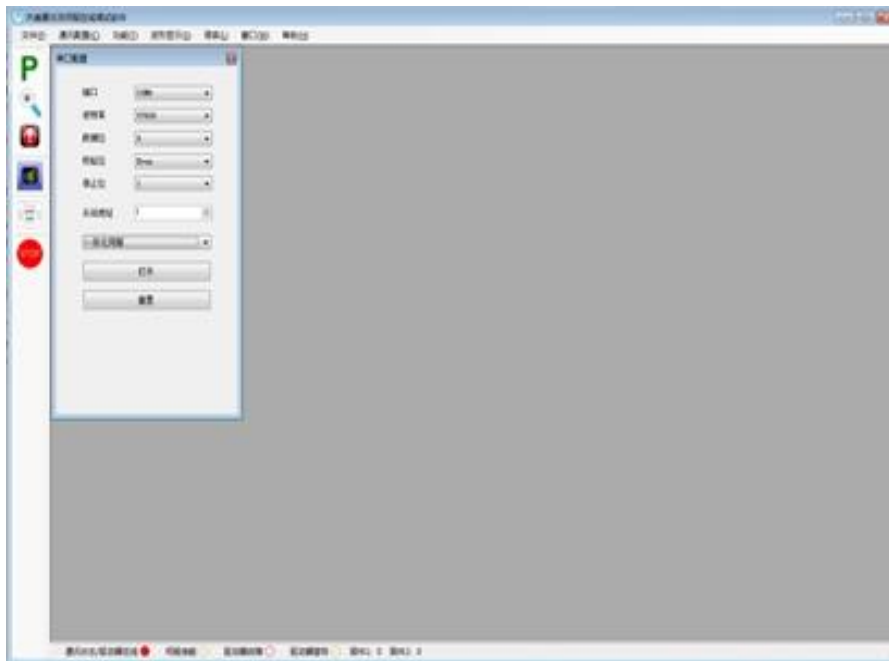

2、In the popup dialog box, set the corresponding options and open at the point, as shown below:



3. If the communication is successful, the following figure shows:



Note: If the connection is not available, please confirm whether COM port is selected correctly, whether the communication line is connected properly, and then reconnect according to the above steps. **Click the upper left option P**

, Then pop up the following window, then the internal parameters of the driver will be uploaded automatically. After uploading, customers can change the parameters according to their needs.

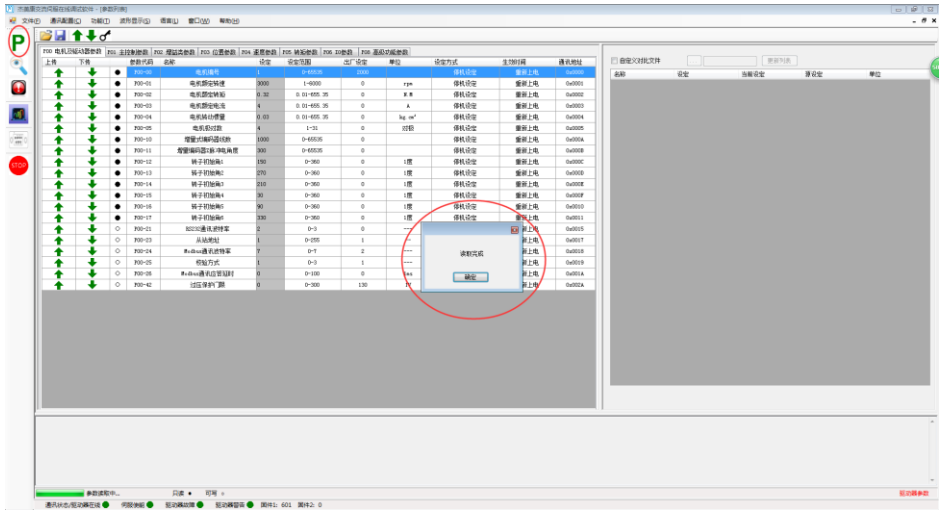

Note: P00-xx is parameters of the motor and drive . The factory has been set up, and will not be changed by customers.

The following three steps are taken as follows: modify, download, upload, as shown in the following figure:



| P00 电机及驱动器参数 | P01 主控制参数 | P02 增益类参数 | P03 位置参数 | P04 速度参数 | P05 转矩参数 | P06 IO参数 | P08 高级功能参 |
|--------------|-----------|-----------|---------------------|----------|----------|----------|-----------|
| 上传 | 下载 | 参数代码 | 名称 | 设定 | 设定范围 | 出厂设定 | 单位 |
| ↑ | ↓ | ○ F01-01 | 控制模式设定 | 0 | 0-6 | 0 | |
| ↑ | ↓ | ○ F01-02 | 实时自动调整模式 | 3 | 0-3 | 1 | |
| ↑ | ↓ | ○ F01-03 | 实时自动调整刚性设定 | 13 | 0-31 | 13 | |
| ↑ | ↓ | ○ F01-04 | 转动惯量比 | 3 | 0-100.00 | 3 | |
| ↑ | ↓ | ○ F01-30 | 抱闸指令-伺服OFF延时时间(抱... | 100 | 0-255 | 50 | |
| ↑ | ↓ | ○ F01-31 | 抱闸指令输出的速度限制值 | 100 | 0-3000 | 100 | |
| ↑ | ↓ | ○ F01-32 | 伺服OFF抱闸指令等待时间 | 100 | 0-255 | 50 | |

Note: After setting the corresponding parameters in the settings, download the changed parameters to the driver according to the download option, and then upload the parameters to the interface to verify whether the parameters have changed.