

*User Manual*

# **CL57T**

Closed Loop Stepper Drive

## Notice

Read this manual carefully before any assembling and using. Incorrect handling of products in this manual can result in injury and damage to persons and machinery. Strictly adhere to the technical information regarding installation requirements.

This manual is not for use or disclosure outside of Leadshine except under permission. All rights are reserved. No part of this manual shall be reproduced, stored in retrieval form, or transmitted by any means, electronic, mechanical, photocopying, recording, or otherwise without approval from Leadshine. While every precaution has been taken in the preparation of the book, Leadshine assumes no responsibility for errors or omissions. Neither is any liability assumed for damages resulting from the use of the information contained herein.

This document is proprietary information of Leadshine that is furnished for customer use ONLY. Information in this document is subject to change without notice and does not represent a commitment on the part of Leadshine. Therefore, information contained in this manual may be updated from time-to-time due to product improvements, etc., and may not conform in every respect to former issues.

## Record of Revisions

Revision	Date	Description of Release
1.0	Mar, 2017	Initial Release

## Table of Contents

<b>1. Introductions</b> .....	1
1.1 Features.....	1
1.2 Applications.....	1
<b>2. Specifications</b> .....	1
2.1 Electrical Specifications.....	1
2.2 Environment.....	1
2.3 Mechanical Specifications.....	2
2.4 Elimination of Heat.....	2
<b>3. Connection Interface and LED Indication</b> .....	2
3.1 Connector P1 Interface.....	3
3.1.1 Pin Assignments of P1.....	3
3.1.2 Control Signal Wiring(P1).....	3
3.2 Connector P2.....	4
3.2.1 Pin Assignments of P2.....	4
3.2.2 Motor and Power Supply Wiring(P2).....	4
3.3 Connector P3.....	5
3.3.1 Pin Assignments of P3.....	5
3.3.2 Motor Encoder Cable Pin-Out.....	5
3.4 Connector P4.....	5
3.5 LED Light Indication.....	6
<b>4. Power Supply Selection</b> .....	6
4.1 Regulated or Unregulated Power Supply.....	6
4.2 Power Supply Sharing.....	6
4.3 Selecting Supply Voltage.....	6
<b>5. DIP Switch Configurations</b> .....	7
5.1 Microstep Resolution(SW1-SW4).....	7
5.2 Other DIP Switch Setting(SW5-SW8).....	7
<b>6. Typical Connection</b> .....	8
<b>7. Sequence Chart of Control Signals</b> .....	8
<b>8. Protection Functions</b> .....	9
<b>9. Troubleshooting</b> .....	10
<b>10. Warranty</b> .....	11

## 1. Introductions

This **Closed Loop Stepper Drive**, offers an alternative for applications requiring higher performance and higher reliability than open loop stepper system, and it remains cost-effective. The matched stepper motors are NEMA17,23 and 24 combined with an internal encoder which is used to close the position, velocity and current loops in real time.

### 1.1 Features

- Input voltage 24-48VDC, output peak current 0-7.0A
- Closed-loop, eliminates loss of synchronization
- No Tuning and always stable
- Do not need a high torque margin
- Broader operating speed range
- Reduced motor heating and more efficient
- Smooth motion and super-low motor noise
- Protections for over-voltage, over-current and position following error

### 1.2 Applications

Its great features of quicker response and no hunting make Leadshine's closed loop stepper drive is ideal for applications such as bonding and vision systems in which rapid motions with a short distance are required and hunting would be a problem. And it is ideal for applications where the equipment uses a belt-drive mechanism or otherwise has low rigidity and you don't want it to vibrate when stopping.

## 2. Specifications

### 2.1 Electrical Specifications

Parameters	CL57T			
	Min	Typical	Max	Unit
Output Current	0	-	7.0(Peak)	A
Supply Voltage	24	36	48	VDC
Logic signal current	7	10	16	mA
Pulse input frequency	0	-	200	kHz
Minimal pulse width	2.5	-	-	μS
Minimal direction setup	5.0	-	-	μS
Isolation resistance	500			MΩ

### 2.2 Environment

Cooling	Natural Cooling or Forced cooling	
Operating Environment	Environment	Avoid dust, oil fog and corrosive gases
	Ambient Temperature	0°C — 65°C (32°F - 149°F)
	Humidity	40%RH—90%RH
	Operating Temperature	0°C — 50°C (32°F - 122°F)
	Vibration	10-50Hz / 0.15mm

Storage Temperature	-20°C — 65°C (-4°F - 149°F)
Weight	Approx. 280 g (9.9 oz)

### 2.3 Mechanical Specifications

(unit: mm [1inch=25.4mm])

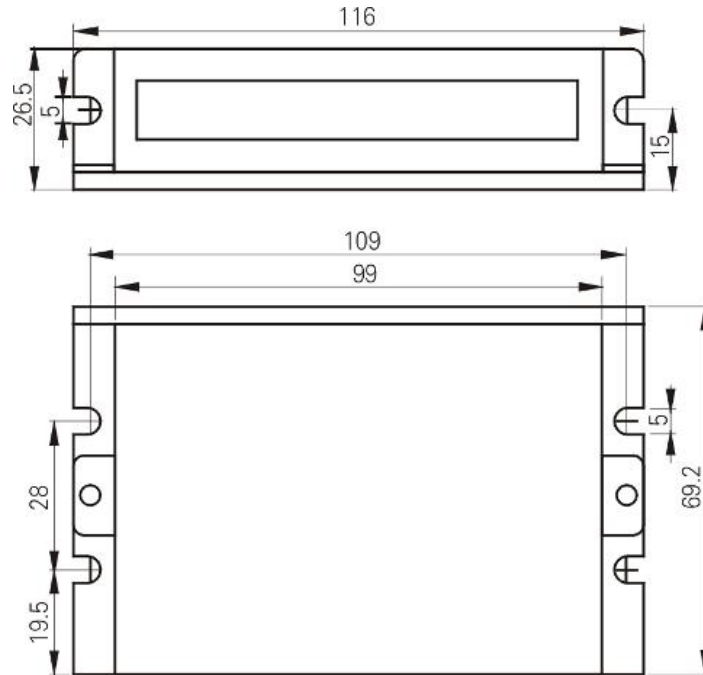

Figure 1: Mechanical specifications

**\* Side mounting recommended for better heat dissipation**

### 2.4 Elimination of Heat

- CL57T reliable working temperature should be < 60°C (140°F)
- It is recommended to mount the drive vertically to maximize heat sink area. Use forced cooling method to cool if necessary.

## 3. Connection Interface and LED Indication



The CL57T has four connector blocks P1&P2&P3&P4 (see above picture). P1 is for control signals connections, P2 is for power and motor connections, P3 is for encoder signals input connections, and P4 is for connecting with PC tuning software. The following tables are brief descriptions of the four connectors. More detailed descriptions of the pins and

related issues are presented in section 4, 5, 9.

### 3.1 Connector P1 Interface

#### 3.1.1 Pin Assignments of P1

Pin Name	I/O	Details
PUL+	I	<b>Pulse signal:</b> In single pulse mode (setting by DIP switch SW7), 4.5-24V when PUL-HIGH, 0-0.5V when PUL-LOW. The same as DIR and ENA signals. Minimal pulse width of 2.5 $\mu$ s and dutycycle of pulse is recommended 50%. In double pulse mode, this input represents clockwise (CW) pulse, active both at high level and low level.
PUL-	I	
DIR+	I	<b>DIR signal:</b> In single pulse mode, this signal has low/high voltage levels to represent two directions of motor rotation. Minimal direction setup time of 5 $\mu$ s. Also swapping the connection of two wires of a coil (e.g. A+ and A-) to the drive will reverse motor direction. In double pulse mode, this signal is counter-clock (CCW) pulse, active both at high level and low level.
DIR-	I	
ENA+	I	<b>Enable signal:</b> This signal is used for enabling/disabling the drive. High level 4.5-24V (NPN control signal) for enabling the drive and low level for disabling the drive. PNP and Differential control signals are on the contrary, namely Low level for enabling. By default it is left <b>UNCONNECTED (ENABLED)</b> .
ENA-	I	
ALM+	O	<b>Fault Signal:</b> OC output signal, active when one of the following protection is activated: over-voltage, over current, short circuit and position following error. This port can sink or source 20mA current at 24V. In default, the resistance between ALM+ and ALM- is low impedance in normal operation and become high when the drive goes into error. The active level of alarm signal can be configured by Leadshine ProTuner.
ALM-	O	



**Notes:** (1) shielding control signal wires is suggested; (2) To avoid interference, don't tie PUL/DIR control signal and motor wires together;(3) No need connect resistance for 12V or 24V control signal.

#### 3.1.2 Control Signal Wiring(P1)

The CL57T can accept differential and single-ended inputs (including open-collector and PNP output). The CL57T has 3 optically isolated logic inputs which are located on connector P1 to accept line drive control signals. These inputs are isolated to minimize or eliminate electrical noises coupled with the drive control signals. Recommend using line drive control signals to increase noise immunity for the drive in interference environments. In the following figures, connections to open-collector and PNP signals are illustrated.

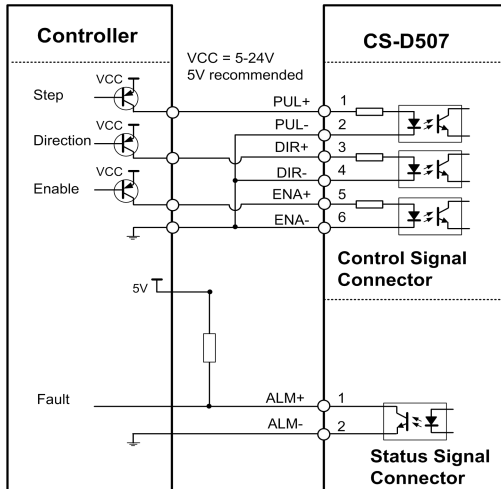
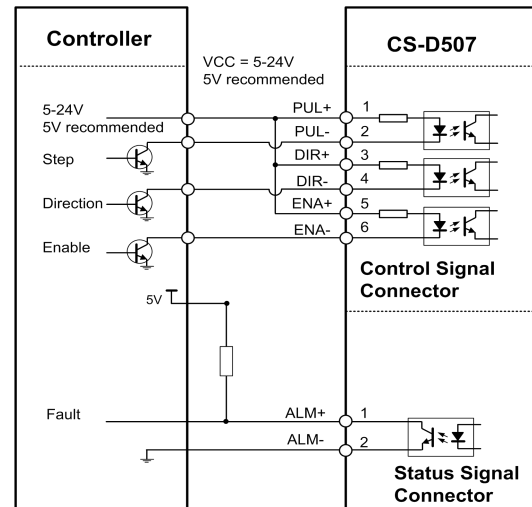
 Figure 2: Connections to PNP signal  
 (common-cathode)

 Figure 3: Connections to open-collector signal  
 (common-anode)

## 3.2 Connector P2

### 3.2.1 Pin Assignments of P2

Pin Name	Details
A+, A-	Motor Phase A connections. Connect motor A+ wire to A+ Pin; motor A- wire to A-
B+, B-	Motor Phase B connections. Connect motor B+ wire to B+ Pin; motor B- wire to B-
+Vdc	Power supply positive connection. Suggest 24-48VDC power supply voltage
GND	Power supply ground connection.



**Warning:** Don't plug or unplug the P1 & P2 terminal block to avoid drive damage or injury when CL57T is powered on.

### 3.2.2 Motor and Power Supply Wiring(P2)

The CL57T can drive NEMA17, 23 and 24 closed loop stepper motor with encoder resolution of 1000 ppr. The current loop PID will be adjusted automatically regarding to function of motor auto-identification and parameter auto-configuration, to output optimal torque from wide-range motors. However, the user can also configure the current in the tuning software. The configurable parameters include motor peak current, closed loop holding current, micro step and etc.

	ES-M22310	ES-M22320	ES-M22430	Wiring Diagram
<b>Step Angle (Degree)</b>	1.8	1.8	1.8	
<b>Holding Torque (N.m)</b>	1.0	2.0	3.0	
<b>Phase Current (A)</b>	4.0	5.0	5.0	
<b>Phase Resistance (Ohm)</b>	0.5	0.4	0.45	
<b>Phase Inductance (mH)</b>	1.9	1.8	2.0	
<b>Inertia (g.cm<sup>2</sup>)</b>	280	480	690	

Weight (Kg)	0.9	1.2	1.5
Encoder (ppr)	1000	1000	1000



**Warning:** For NEMA17 closed loop motor, need to change the value of motor peak current from 80 to 30, if not, it will burning the motor as too high current output.

### 3.3 Connector P3

#### 3.3.1 Pin Assignments of P3

Drive Pin Name	Description	Encoder Extension Cable Color
EB+	Encoder B+ input	Yellow
EB-	Encoder B- input	Green
EA+	Encoder A+ input	Black
EA-	Encoder A- input	Blue
VCC	+5V power input	Red
EGND	Power ground	White

#### 3.3.2 Motor Encoder Cable Pin-Out

##### ES-M22310, ES-M22320

Pin	Name	Wire Color	I/O	Description
1	EA+	Black	O	Channel A+ output
2	VCC	Red	I	+5V power input
3	GND	White	GND	Ground
11	EB+	Yellow	O	Channel B+ output
12	EB-	Green	O	Channel B- output
13	EA-	Blue	O	Channel A- output

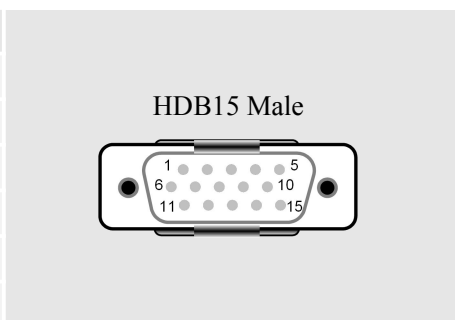

### 3.4 Connector P4

It is a RS232 communication port using to connect with PC software to configure the motor peak current, closed loop holding current, microstep, active level.

RS232 Communication Port – RJ11			
Pin	Name	I/O	Description
1	NC	-	Not connected.
2	+5V	O	+5V power output.
3	TxD	O	RS232 transmit.
4	GND	GND	Ground.
5	RxD	I	RS232 receive.
6	NC	-	Not connected.

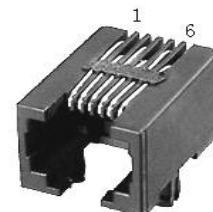



### 3.5 LED Light Indication

There are two LED lights for CL57T. The GREEN one is the power indicator which will be always on generally. The RED one is a protection indicator which will flash 1,2 or 7 times in a 5-second period, when protection enabled for a CL57T. Different number of flashes indicates different protection type (read section 8 for detail).

## 4. Power Supply Selection

The CL57T can power medium and small size closed loop stepper motors (frame size from NEMA17 to 34) made by Leadshine or other motor manufacturers. To get good driving performances, it is important to select supply voltage and output current(by configuring motor peak current) properly. Generally speaking, supply voltage determines the high speed performance of the motor, while output current determines the output torque of the driven motor (particularly at lower speed). Higher supply voltage will allow higher motor speed to be achieved, at the price of more noise and heating. If the motion speed requirement is low, it's better to use lower supply voltage to decrease noise, heating and improve reliability.

### 4.1 Regulated or Unregulated Power Supply

Both regulated and unregulated power supplies can be used to supply the drive. However, unregulated power supplies are preferred due to their ability to withstand current surge and fast response for current change. If you prefer to a regulated power supply, it is suggested to choose such a power supply specially designed for stepper/servo controls Or, in the case when only normal switching power supplies are available, it is important to use "OVERSIZE" high current output rating power supplies (for example, using a 4A power supply for 3A stepper motor) to avoid problems such as current clamp. On the other hand, if unregulated supply is used, one may use a power supply of lower current rating than that of motor (typically 50%~70% of motor current). The reason is that the drive draws current from the power supply capacitor of the unregulated supply only during the ON duration of the PWM cycle, but not during the OFF duration. Therefore, the average current withdrawn from power supply is considerably less than motor current. For example, two 3A motors can be well supplied by one power supply of 4A rating.

### 4.2 Power Supply Sharing

Multiple CL57T drives can share one power supply to reduce cost, if that power supply has enough power capacity. To avoid cross interference, connect each stepper drive directly to the shared power supply separately. To avoid cross interference, DO NOT daisy-chain connect the power supply input pins of the Drivers. Instead connect them to power supply separately.

### 4.3 Selecting Supply Voltage

The CL57T is designed to operate within +24 - +48VDC voltage input. When selecting a power supply, besides voltage from the power supply power line voltage fluctuation and back EMF voltage generated during motor deceleration needs also to be taken into account. Ideally it is suggested to use a power supply with the output of +36VDC, leaving room for power line voltage fluctuation and back -EMF.

Higher supply voltage can increase motor torque at higher speeds, thus helpful for avoiding losing steps. However, higher voltage may cause bigger motor vibration at lower speed, and it may also cause over-voltage protection or even drive damage. Therefore, it is suggested to choose only sufficiently high supply voltage for intended applications.

## 5. DIP Switch Configurations

This drive uses an 8-bit DIP switch to set microstep resolution, motor direction, auto tuning switch and so on.

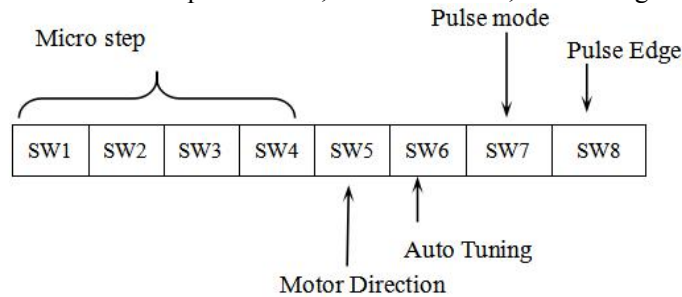

### 5.1 Microstep Resolution(SW1-SW4)

Microstep resolution is set by SW1, 2, 3, 4 of the DIP switches as shown in the following table:

Steps/Revolution	SW1	SW2	SW3	SW4
<b>Software Configured (Default 1600)</b>	on	on	on	on
<b>800</b>	off	on	on	on
<b>1600</b>	on	off	on	on
<b>3200</b>	off	off	on	on
<b>6400</b>	on	on	off	on
<b>12800</b>	off	on	off	on
<b>25600</b>	on	off	off	on
<b>51200</b>	off	off	off	on
<b>1000</b>	on	on	on	off
<b>2000</b>	off	on	on	off
<b>4000</b>	on	off	on	off
<b>5000</b>	off	off	on	off
<b>8000</b>	on	on	off	off
<b>10000</b>	off	on	off	off
<b>20000</b>	on	off	off	off
<b>40000</b>	off	off	off	off

### 5.2 Other DIP Switch Setting(SW5-SW8)

	Function	On	Off
<b>SW5</b>	Default Direction <i>Note</i>	CW (clock-wise)	CCW (counter-clock-wise)
<b>SW6</b>	Auto Tuning	No	Yes
<b>SW7</b>	Pulse Model	CW/CCW(double pulse)	PUL/DIR(single pulse)
<b>SW8</b>	Pulse Edge	Falling	Rising



**Notes:** (1) The factory setting of DIP switch are ‘on off on on off off off off’; (2) The default direction is related to the DIR level, you can toggle SW5 to change it .

## 6. Typical Connection

A complete closed loop stepper system should include closed loop motor, drive, power supply and controller (pulse generator). A typical connection is shown as figure 9.

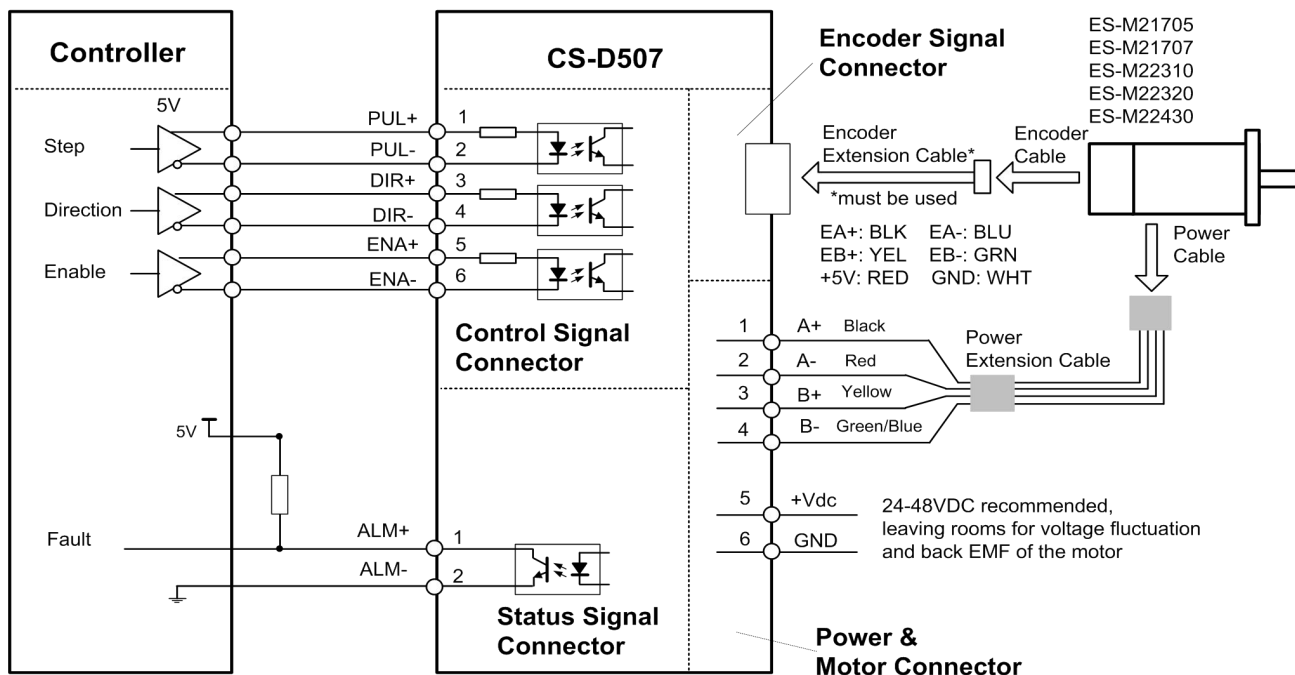

Figure 9: Typical connection

## 7. Sequence Chart of Control Signals

In order to avoid some fault operations and deviations, PUL, DIR and ENA should abide by some rules, shown as following diagram:

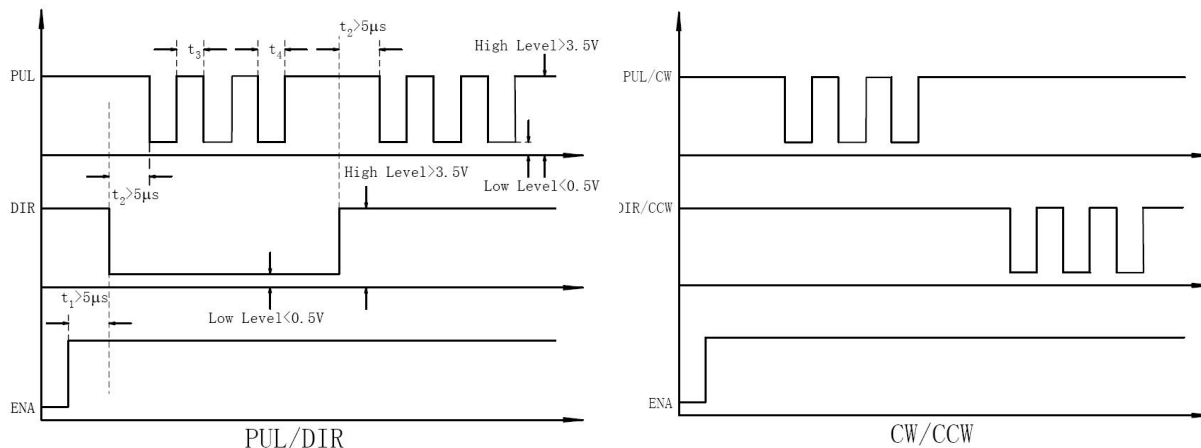

Figure 10: Sequence chart of control signals

**Remark:**

- a) t1: ENA must be ahead of DIR by at least 5 $\mu$ s. Usually, ENA+ and ENA- are NC (not connected). See “Connector P1 Configurations” for more information.
- b) t2: DIR must be ahead of PUL effective edge by 5 $\mu$ s to ensure correct direction;
- c) t3: Pulse width not less than 2.5 $\mu$ s;
- d) t4: Low level width not less than 2.5 $\mu$ s.

## 8. Protection Functions

To improve reliability, the drive incorporates some built-in protections features.

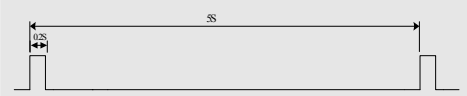
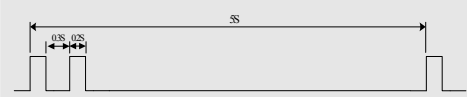
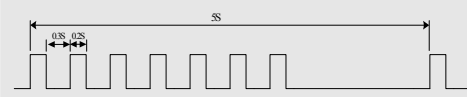
Priority	Time(s) of Blink	Sequence wave of red LED	Description
1st	1		Over-current protection activated when peak current exceeds the limit.
2nd	2		Over-voltage protection activated when drive working voltage is greater than 90VDC
3rd	7		Position following error

When above protections are active, the motor shaft will be free or the red LED blinks. Reset the drive by repowering it to make it function properly after removing above problems.

## 9. Troubleshooting

In the event that your drive doesn't operate properly, the first step is to identify whether the problem is electrical or mechanical in nature. The next step is to isolate the system component that is causing the problem. As part of this process you may have to disconnect the individual components that make up your system and verify that they operate independently. It is important to document each step in the troubleshooting process. You may need this documentation to refer back to at a later date, and these details will greatly assist our Technical Support staff in determining the problem should you need assistance.

Many of the problems that affect motion control systems can be traced to electrical noise, controller software errors, or mistake in wiring.

### Problem Symptoms and Possible Causes

Symptoms	Possible Problems
<b>Motor is not rotating</b>	No power
	Microstep resolution setting is wrong
	Fault condition exists
	The drive is disabled
<b>Motor rotates in the wrong direction</b>	The Direction signal level is reverse
<b>The drive in fault</b>	Power supply voltage beyond drive's input range
	Something wrong with motor coil
	Wrong connection
<b>Erratic motor motion</b>	Control signal is too weak
	Control signal is interfered
	Wrong motor connection
	Something wrong with motor coil
<b>Motor stalls during acceleration</b>	Current setting is too small
	Motor is undersized for the application
	Acceleration is set too high
	Power supply voltage too low
<b>Excessive motor and drive heating</b>	Inadequate heat sinking / cooling
	Motor peak current setting is too high
<b>Motor vibration when power on</b>	Speed loop Kp is too high

## **10. Warranty**

### **Twelve Month Warranty**

OMC Co., Ltd. warrants its products against defects in materials and workmanship for a period of 12 months from shipment out of factory. During the warranty period, Leadshine will either, at its option, repair or replace products which proved to be defective.

### **Exclusions**

The above warranty does not extend to any product damaged by reasons of improper or inadequate handlings by customer, improper or inadequate customer wirings, unauthorized modification or misuse, or operation beyond the electrical specifications of the product and/or operation beyond environmental specifications for the product.

### **Obtaining Warranty Service**

*To obtain warranty service, please contact your seller to obtain a returned material authorization number (RMA) before returning product for service.*

### **Shipping Failed Products**

If your product fail during the warranty period, please contact your seller for how and where to ship the failed product for warranty or repair services first, you can also e-mail customer service at [customer@omc-stepperonline.com](mailto:customer@omc-stepperonline.com) to obtain a returned material authorization number (RMA) before returning product for service. Please include a written description of the problem along with contact name and address.